

# WESTMILL

The Leader in Veneer Drying Technologies

New Dryers | Dryer Upgrades | Innovative Designs | Quality Components

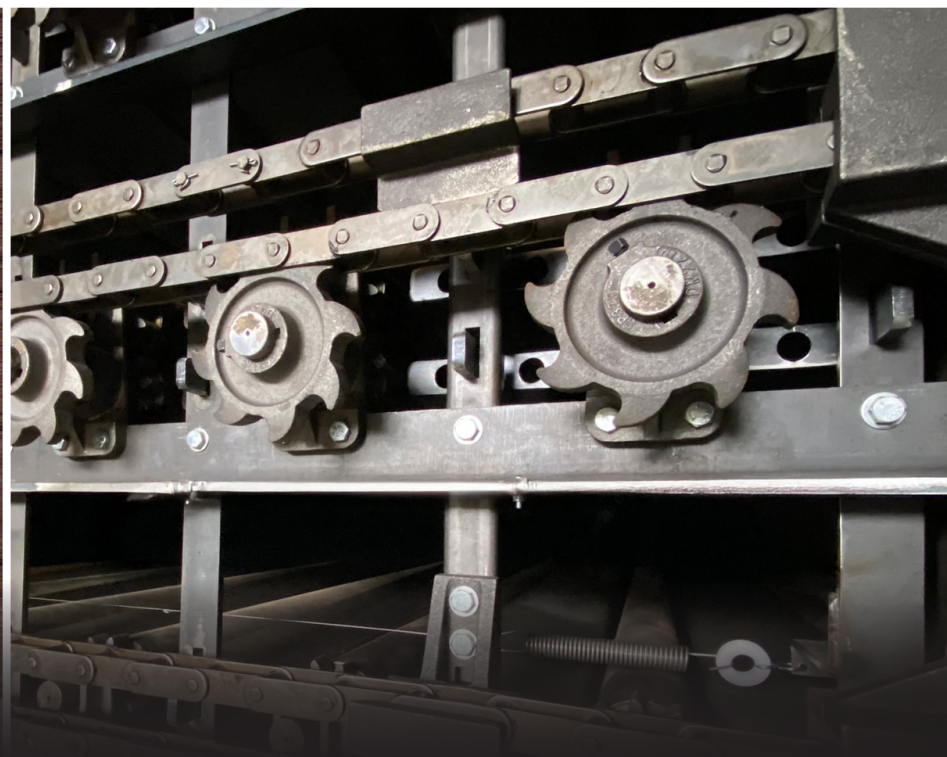

## VENEER DRYER PARTS CATALOGUE

VERSION 16



*Established in 1975 by Victor Crondahl, Westmill Industries started supplying critical replacement parts and equipment to the North American plywood manufacturing industry. More than five decades later Westmill has become a world leader in the design and manufacture of veneer drying equipment and technologies, and continues to grow under its 2nd generation owner Mike Crondahl.*

*Westmill is proud of its longstanding innovative culture and heritage and of the many key dryer patents awarded to it over the past 25+ years. These industry-leading technologies are what set us apart from all others. Westmill remains most proud of being awarded both the **Innovator of the Year** and the **Supplier of the Year** awards as chosen by APA members.*

*Westmill continues to flourish, achieving important industry milestones such as installing the industry's **first** insulated stainless dryer floor (under an existing dryer), to building the **largest-ever** veneer dryer in the world.*

*To our friends and customers worldwide, THANK YOU for entrusting WESTMILL with your dryer service needs, and for helping us to succeed over the past 50 years.*

*Mike Crondahl  
Owner/President*



*Victor Crondahl, founder of Westmill Industries*



*Westmill Industries Team - Vancouver, British Columbia*

# PARTS CATALOGUE TABLE OF CONTENTS

## WESTMILL INDUSTRIES

WESTMILL HISTORY	03
WESTMILL PATENTS	04
WESTMILL VENEER JET DRYER	05
WESTMILL OFFERS	07

## WESTMILL INDUSTRIES

HANGER BEARINGS	09
BEARINGS	10
BEARING HOUSINGS	11
STAR GEARS	13
SPROCKETS	14
CHAIN HOLD DOWNS	16
CHAIN WINDOWS	16
DRYER CHAIN	16
GUDGEONS	17

## ROLL TUBES & ASSEMBLIES

ROLL TUBING	20
WESTMILL JET DRYER	21
COE M-62 JET DRYER	22
COE M-72 JET DRYER	23
USNR-208	23
RAUTE WOOD (PRE-2000)	24
RAUTE WOOD (200 & NEWER)	25
COE LONGITUDINAL (15")	26
MOORE JET, STANDARD	27
MOORE LONGITUDINAL (12")	28
MOORE & PRENTICE LONGITUDINAL	28
PRENTICE LONGITUDINAL (12")	29
PRENTICE LONGITUDINAL (15")	29

## MAJOR COMPONENTS

JET TUBES	31
M-72 PLUG FANS	33
SPRING PACKING GLAND SEAL SYSTEM	34
FAN HARDWARE	35
GAS BURNERS	36
STEAM COILS	37

## DRYER DOORS

QUICK-CHANGE 1-2-3™ DOOR SEAL	39
ARTICULATING DOOR HARDWARE	40
DOOR CARTRIDGE	40
WESTMILL DOOR HARDWARE	41
SafeRelease™ HANDLE SYSTEM	43
OEM DOOR HARDWARE	44
TADPOLE DOOR SEALS	45

## GENERAL COMPONENTS

PLUG-UP DETECTION	47
MOISTURE DETECTION	49
MARKING INK	50
DRYER CLEANER	50
EXPANSION ROLLERS	51
GLOBE SAW PARTS	53

**DISCOVER WHAT  
MAKES WESTMILL  
THE LEADER IN  
VENEER DRYING**  
WESTMILL CAPITAL  
EQUIPMENT PAGE 55



CONVEYOR  
COMPONENTS

ROLL TUBES &  
ASSEMBLIES

MAJOR  
COMPONENTS

DRYER DOORS

GENERAL  
COMPONENTS

WESTMILL  
EQUIPMENT



**'99 | FIRST PATENT**  
Westmill Articulating Door Hardware.

**'99 | FIRST NEW LONGITUDINAL DRYER**  
Westmill installs their first new longitudinal dryer for Tolko, in Heffley Creek, BC.

**'05 | LightSORT™ TECHNOLOGY**  
Westmill develops the LightSORT™ technology and installs the first system at Tolko's Kelowna Plywood plant.

**'10 | INNOVATOR OF THE YEAR AWARD**  
Westmill is awarded the APA's prestigious APA/EWTA 2010 'Innovator of the Year'.

**'20 | WESTMILL GROWS AGAIN**  
Expanding in size, Westmill moves to a larger facility in Abbotsford, BC.

**'75 | THE BEGINNING**  
Westmill is established in 1975 by Victor T. Crondahl, father of Mike Crondahl.

1990  
MIKE CRONDAHL JOINS WESTMILL

2002  
1<sup>ST</sup> USA LOCATION OPENS

2008  
2<sup>ND</sup> USA LOCATION OPENS

2025  
WESTMILL CELEBRATES 50 YEARS



**1976 -1989 | CANADIAN GROWTH**

The company secures exclusive Canadian representation of many US product lines inc: Globe, Sweed, and COE.

1996  
MIKE CRONDAHL BECOMES OWNER

**'00 | FIRST EVER INDUSTRY FLOOR RETROFIT**

Westmill installs the Plywood industries first ever retrofit, stainless steel dryer floor at Evans Forest Products in Golden, BC.

**'04 | SELL THEIR FIRST 6-DECK JET DRYER**

Westmill is completed their first 6-deck Jet Dryer for West Fraser in Edmonton, AB.

**'13 | SUPPLIER OF THE YEAR AWARD**

Westmill is awarded the prestigious APA/EWTA 2010 'Supplier of the Year' Award in Materials/Supplies category.

**'24 | WORLD'S LARGEST DRYER COMPLETED**

Westmill is awarded the contract to build the Worlds Largest Veneer Dryer for Roseburg Forest Products.

**'00 | WESTMILL MOVES**  
Growing in size, the company moves to Langley, BC.



## CUTTING-EDGE INNOVATIONS SHAPING TOMORROW

### WESTMILL remains actively engaged in product development initiatives.

Our innovations have led to some of the best-in-class technologies which are being embraced by our performance minded customers. Westmill is proud of its long-term commitment to innovation, and the results they produce.

#### WestVac™ Emission & Dryer Seal System

PATENT NO. 10,006,712 B2 **PATENTED**

Westmill's WestVac Emission & Dryer Seal System seals the dryer's end walls to limit emissions from leaking out of the dryer's green and dry-ends, all while maintaining the optimum humidity level inside the dryer.

#### Quick-Change Dryer Roll Baffle System

PATENT NO. 10,317,138 B2 **PATENTED**

Westmill designed the first-ever, quickly interchangeable Dryer Roll Baffle system. The significant benefit of this innovation is that the existing roll-baffle can be removed and replaced in under 5-minutes, as compared to several hours.

#### UV-IR Veneer Pre-Conditioning Drying Section

PATENT NO. 11,370,145 B2 **PATENTED**

Westmill has built and tested an IR chamber specifically for veneer drying. The concept involves installing a UV-IR pre-conditioning section at the dryer infeed to quickly heat the bound water (and free water) at the core of the sheet, speeding up the start of the drying process, and therefore improving dryer performance.

#### 2-PEX™ Exhaust & Dryer Humidity Control System

PATENT NO. 11,821,684 **PATENTED**

Westmill's 2PEX™ System provides unparalleled control of the humidity ratio along the entire dryer's length resulting in the BEST veneer quality available from any dryer today.

#### Impressed Current Cathodic Protection (ICCP)

PATENT NO. 11,193,211 B2 **PATENTED**

Westmill has developed an effective method of virtually eliminating dryer corrosion, using Impressed Current Cathodic Protection Technology and the humidity within a dryer as the electrolyte. Our patented ICCP System is the first-ever system of its kind applied to a veneer dryer.

#### Westmill Articulating Door Hardware

PATENT NO. 6,447,807 **PATENTED**

The Dura-Latch Articulating Door Hardware is the most functional and easily adjustable door hardware available on the market. The design and geometry of the door handle provide for safe, quick and easy opening and closing without strain.

#### SafeRelease™ Handle System

PATENT NO. 12,071,786 B2 **PATENTED**

When a conventional dryer door is opened, there is a tremendous amount of force on the handle due to the spring compression of the door seal material. When pulled open, the door seal quickly 'loads-up' the handle with striking force. With the new Safe-Openings door handle load-dampener, the force on the door-handle are controlled when opening. Removing the risk of workplace hazards.

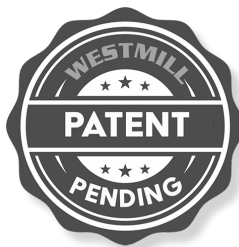

DISCOVER MORE WESTMILL EXCLUSIVE TECHNOLOGY

# WESTMILL VENEER DRYER

## CUSTOMIZED NEW DRYER

Westmill Veneer Dryers are the best available in the industry today. With superior insulating techniques and a completely seal-welded housing, Westmill has designed the most energy-efficient dryer available in the market.

Many features that are optional on other systems are standard equipment on a Westmill Dryer. Our robust designs and quality components will provide you with many years of production and minimum maintenance expense.

## DRYER TECHNOLOGY UPGRADES

As veneer dryers age, the housing begins to leak using more energy to maintain temperature set point. As a result, dryer production drops and maintenance costs rise.

Before making the decision to replace your dryer, consider a Westmill Dryer Technology Upgrade, your dryer will look and operate better than new - often a fraction of the cost of a new dryer.

**AUTOMATED  
DRYER CONTROLS**  
ALLEN-BRADLEY CONTROLLOGIX

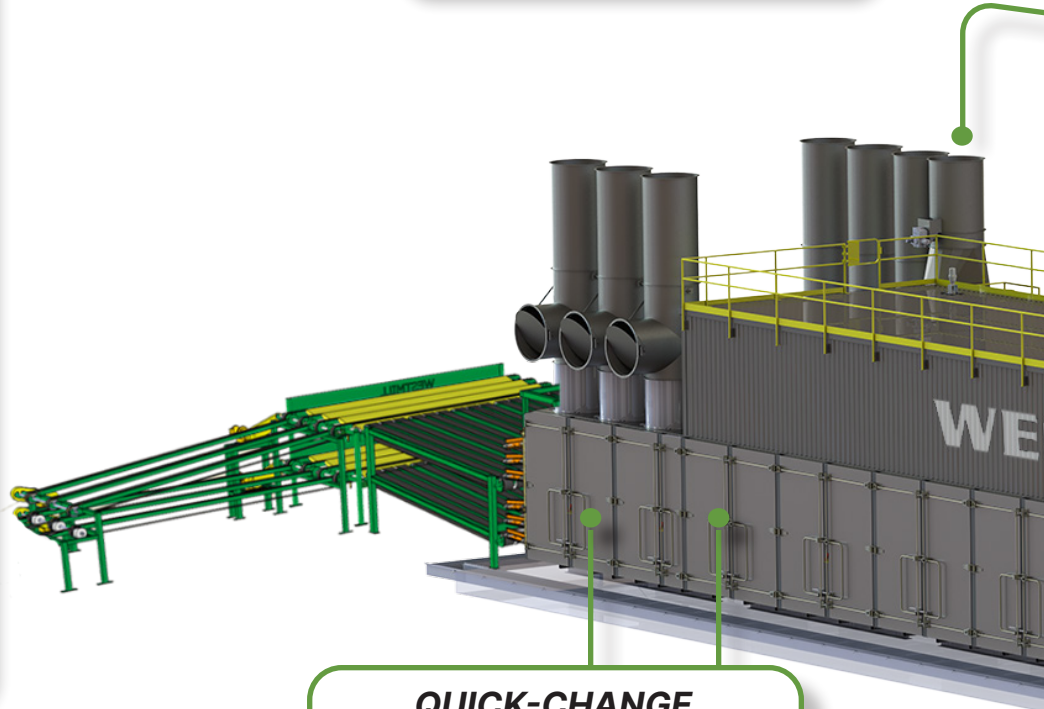

**QUICK-CHANGE  
DRYER ROLL BAFFLE SYSTEM**

**PATENTED**

**ARTICULATING  
DOOR HARDWARE**

**PATENTED**

**SafeRelease™**

**HANDLE SYSTEM**

Eliminate any potential risk of 'strike-hazard' when opening a dryer door.

**PATENTED**

**2-PEX**  
EXHAUST & DRYER HUMIDITY  
MIGRATION AND CONTROL SYSTEM  
**PATENTED**

**WESTVAC**  
END-WALL EMISSION  
AND CONTROL SYSTEM  
**PATENTED**

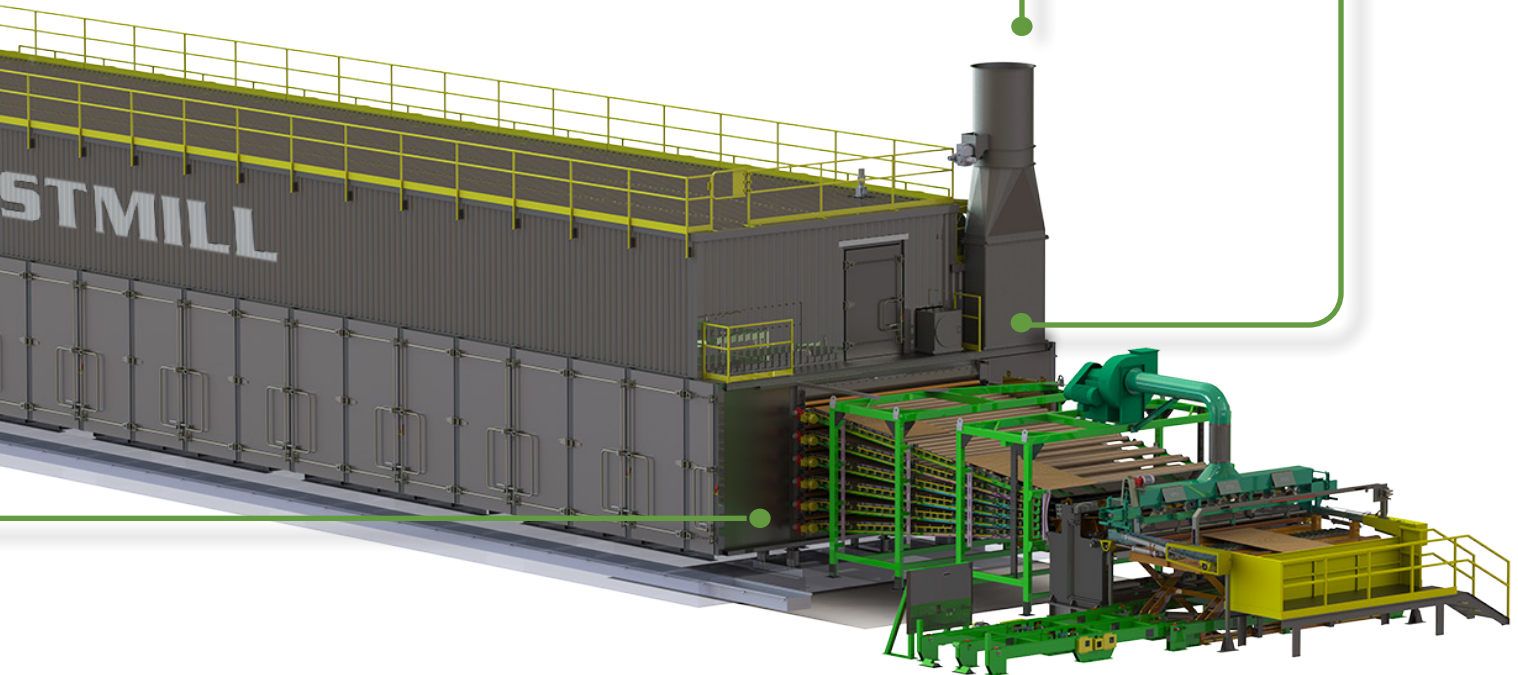

## ADDITIONAL DRYER FEATURES

### Minimal Heat Transfer Dryer Housing

Eliminate metal-to-metal contact between inside and outside dryer housing to reduce heat transfer.

### Quick-Change Dryer Door Seal System

Change door seals in under 5 minutes.

### Dryer Floor

Stainless steel, seal welded and insulated; rust-proof for long life.

### Water Misting System

Greatly reduces the risk of dryer fires caused by fuel build-up and embers.

### Drive Tower

Individual deck drives for minimum maintenance, accurate speed control and maximum veneer recovery in the event of a plug-up.

### Dryer Humidity & Emissions Control

Westmill's innovative WestVac and 2PEX Systems combine to maintain optimum humidity levels inside the dryer to consistently produce high-quality veneer, minimize energy consumption while maximizing production.

### Jet Tubes

Our jet tubes feature high-velocity orifices for maximum air flow and heat transfer to the veneer.

# WESTMILL OFFERS



**Serving the panel board industry since 1975, Westmill has emerged as North America's leading dryer specialist.**

A leader in board drying technologies, Westmill specializes in supplying new veneer dryer systems, dryer technology upgrades, and is the largest stocking supplier of dryer parts in the world. Westmill is committed to providing Veneer Dryer Innovations.

#### **Westmill Offers:**

- Customized New Dryers
- Dryer Rebuilds & Upgrades
- Dryer Parts for all Makes & Models
- Inspections & Consulting
- Infeed & Outfeed Equipment
- Exclusive Innovative Technologies

*"We really appreciate the support that WESTMILL provides. Their dryers are high quality and their service is some of the best!"*

*Mike Rudy - Director of Manufacturing (Plywood), Timber Products*

**WAREHOUSES IN VANCOUVER, BC | EUGENE, OR | ATLANTA, GA**



# SHOP ONLINE

## PARTS FOR ALL DRYER MODELS

Get in touch at 1 877 607-7010 Contact us

**WESTMILL**

Bearing Housing Bushing Chain Guides Doors Gears Gudgeons Hanger Bearings Jet Tubes Rolls/Assemblies Misc Parts

### WESTMILL ONLINE STORE

Innovative technology & exceptional customer service

Westmill Industries is committed to helping their customers achieve success with higher production rate as well as more energy-efficient dryers.

#### Bearing Housing

Westmill™ stocks a wide range of Bearing Housing Parts [View all](#)

- B372 - Bearing Housing, 35mm OD x 25mm ID, Babcock
- B368 - Bearing Housing, Idler (Cooler Section)
- B162 - Bearing Housing, Prentice
- B161 - Bearing Housing, Drive Side, Closed Back
- B363 - Roll Housing, Moore, Cast Iron

WESTMILL ONLINE STORE

Innovative technology & exceptional customer service

Westmill Industries is committed to helping their customers achieve success with higher production rate as well as more energy-efficient dryers.

Bearing Housing

Westmill™ stocks a wide range of Bearing



**SIGN UP TODAY!** [parts.westmill.com](https://parts.westmill.com)



# HANGER BEARINGS

CONVEYOR COMPONENTS



BU27



BU28

ROLL TUBES & ASSEMBLIES

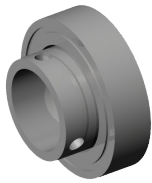

BU29



BU30

MAJOR COMPONENTS

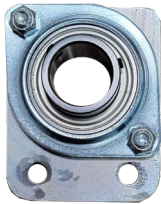

WM-113



WM-116C

DRYER DOORS



WM-116D

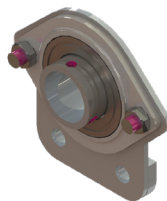

WM-113-GP

WESTMILL PART NO.	CROSS REF.	PART DESCRIPTION	BORE SIZE
BU27	C-76113-2SSB	Infeed Hanger Bearing (flat back)	1-1/4"
BU28	C-76116-2SSB	Infeed Hanger Bearing (over angle)	1-1/4"
BU29	-	Replacement Sealed Bearing Insert for Hanger Bearings (WM-113, 116 and 116C)	1-1/4"
BU30	C-237	Bearing, Hanger, 4-Hole, Flat-Back	1-1/4"
WM-113	C-76113-2SSB	Infeed Hanger Bearing (flat back) with Replaceable Sealed Bearing Insert (BU29)	1-1/4"
WM-116C	C-76116-2SSB	New Infeed Hanger Bearing (over angle) with Replaceable Sealed Bearing Insert (BU29)	1-1/4"
WM-116D	-	Bearing Assembly, Sealed Insert, 4-Hole, Flat-Back	1-1/4"
WM-113-GP	C-76116-2SSB	Board Mill Bearing (flat back) with Replaceable Sealed Bearing Insert (BU29)	1-1/4"

GENERAL COMPONENTS

**STOCKING THE MOST PARTS IN THE WORLD**  
**WE'VE GOT YOUR BACK**

Westmill warehouses stock the largest variety of dryer parts and can supply components for **all makes and models**. With three warehouses located across North America.

**Warehouse Locations:** Vancouver, BC • Eugene, OR • Atlanta, GA

WESTMILL EQUIPMENT

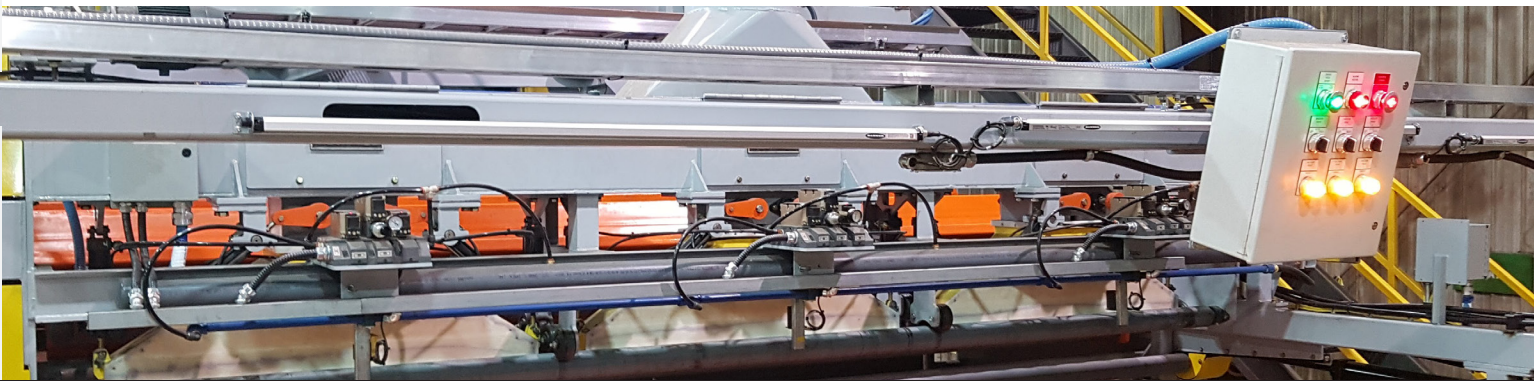

WESTMILL PART NO.	COMPATIBLE DRYERS	BORE SIZE	OUTER DIAMETER	LENGTH THRU BORE
-------------------	-------------------	-----------	----------------	------------------

### DRIVING FORCE™ EXTENDED LIFE BEARING

BU34W	Westmill, COE (Cooler Section, Raised Rolls)	1-1/2"	2"	1-1/2"
BU15W	Raute	25mm	45mm	38mm
BU13W	Raute	1"	1-3/4"	1-7/16"
BU14W	Raute (Stepped)	1"	1-3/4"	2-1/8"
BU31W	Westmill, COE, USNR, Moore & Prentice Long. (Std)	1-1/2"	2-1/2"	1-3/4"
BU21W	Moore	1-1/4"	2"	2-1/4"



Driving Force™ Bearing BU31W

### TEFLON BEARING

BU12	Moore	1"	1-1/2"	1-1/2"
BU13	Raute	1"	1-3/4"	1-7/16"
BU14	Raute (Stepped)	1"	1-3/4"	2-1/8"
BU15	Raute	25mm	45mm	38mm
BU21	Moore	1-1/4"	2"	2-1/4"
BU26	COE (Infeed Section), Moore Jet	1-1/4"	2-1/2"	1-3/4"
BU34	Westmill, COE (Cooler Section, Raised Rolls)	1-1/2"	2"	1-1/2"
BU31	Westmill, COE, USNR, Moore & Prentice Long. (Std)	1-1/2"	2-1/2"	1-3/4"

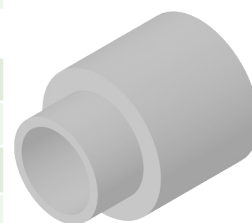

Driving Force™ Bearing BU14W

### GRAPHITE BEARING

BU91	Babcock	18mm (0.71")	26mm (1.02")	28.5mm (1.12")
BU92	Babcock	25mm (0.98")	35mm (1.38")	30mm (1.18")
BU22	Moore	1-1/4"	2"	2-1/4"
BU15G	Raute	25mm	45mm	38mm
BU15GI	Raute	1"	1-3/4"	1-1/2"
BU43	COE M72	1-1/2"	2"	1-1/4"
BU24	COE (Infeed Section), Moore Jet	1-1/4"	2-1/2"	1-3/4"
BU32	Westmill, COE, USNR, Moore & Prentice Long. (Std)	1-1/2"	2-1/2"	1-3/4"

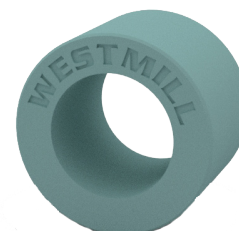

Teflon Dryer Bearing BU31

### COPPER IMPREGNATED GRAPHITE BEARING

BU39C	COE	1-1/4"	2-1/2"	1-3/4"
BU34C	Westmill, COE (Cooler Section, Raised Rolls)	1-1/2"	2"	1-1/2"
BU92C	Raute Jet	25mm	35mm	30mm
BU33C	Westmill, COE, USNR, Moore & Prentice Long. (Std)	1-1/2"	2-1/2"	1-3/4"



Standard Graphite Bearing BU32

CONVEYOR COMPONENTS

ROLL TUBES & ASSEMBLIES

MAJOR COMPONENTS

DRYER DOORS

GENERAL COMPONENTS

WESTMILL EQUIPMENT

# BEARING HOUSINGS

CONVEYOR COMPONENTS



B161



B162

ROLL TUBES & ASSEMBLIES



B163



B261

MAJOR COMPONENTS



B262



B263

DRYER DOORS



B361



B362

GENERAL COMPONENTS



B365



B366

WESTMILL PART NO.	CROSS REF.	PART APPLICATION	BORE SIZE
B161	8212, PC072115	Westmill, COE M72 Drive Side Closed Back	2-1/2"
B162	Prentice C-30	Bolts to C006 (NW-64) Chain Hold down Replaces Moore RD-65 and RD-165	2-1/2"
B163	10499	COE M-62 Drive Side	2-1/2"
B261	10497, PC072113	Westmill, COE M62/M72 Idler Side	2-1/2"
B262	PC072113L	Bearing Housing, Extended, Idler Side, Seal Section	2-1/2"
B263	Moore RD-161 COE 619-2006-00	Moore: Top Roll Guide	2-1/2"
B361	Moore RD-165	For Moore Dryer with 12" vertical deck spacing (short casting)	2-1/2"
B362	Moore RD-65 Prentice C-2	For Moore Dryer with 15" vertical deck spacing	2-1/2"
B365	COE PB-016048 8281RH	COE: At door post notched at right	2-1/2"
B366	COE PB-016048 8281LH	COE: At door post notched at left	2-1/2"

WESTMILL EQUIPMENT



WESTMILL PART NO.	CROSS REF.	PART APPLICATION	BORE SIZE
B367	PB-034280 10895A	Westmill, COE: Drive Side raises top roll, Cooler	2-1/2"
B368	PB-034281 10893A	Westmill, COE: Idler Side raises top roll, Cooler	2-1/2"
B331	Raute Wood 4R708667	Raute Wood: Drive and Idler side	1-3/4"
B331-M	Raute Wood 4R50430GKK	Raute Wood: Drive and Idler side	45mm (1.77")
B363	Moore RD-162 COE 619-2007-00	Drive and Idler side	2"
B371	Moore RD-161 COE 619-2006-00	Moore: Top Roll Guide	1-11/6"
B369	Babcock 4-bolt	Babcock: Screen Dryer	45mm (1.77")
B370	Babcock 4-bolt	Babcock: Screen Dryer	45mm (1.77")
B372	8001645	Babcock, 35mm OD x 25mm ID Bearing	35mm
B376	Moore RD-65 Prentice C-2	For Moore Dryer with 15" vertical deck spacing	2-1/2"



B367



B368



B331



B331-M

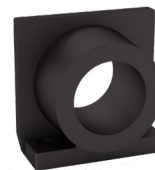

B363



B371

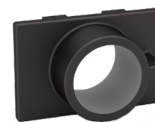

B369

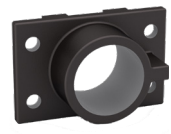

B370



B372

CONVEYOR  
COMPONENTS

ROLL TUBES &  
ASSEMBLIES

MAJOR  
COMPONENTS

DRYER DOORS

GENERAL  
COMPONENTS

WESTMILL  
EQUIPMENT

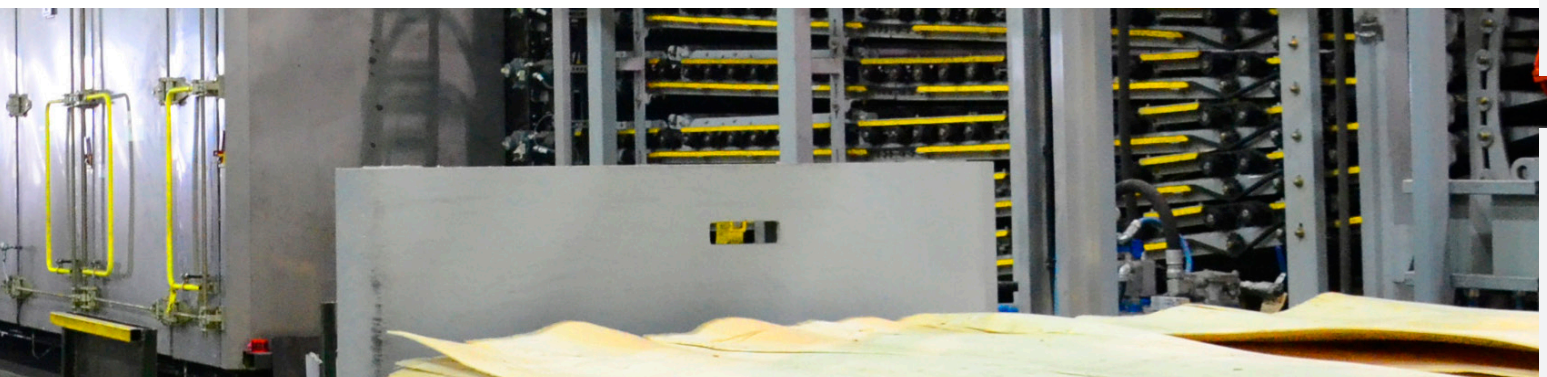

# STAR GEARS

CONVEYOR COMPONENTS

ROLL TUBES & ASSEMBLIES

MAJOR COMPONENTS

DRYER DOORS

GENERAL COMPONENTS

WESTMILL EQUIPMENT

WESTMILL PART NO.	CROSS REFERENCE	TEETH	HUB STYLE	BORE	KEY WAY	LENGTH THRU BORE	TOOTH WIDTH
S213	Moore RD-130	10	A	1-1/4"	1/4"	15/16"	13/16"
S221	Moore RD-130	10	A	1-1/4"	3/8"	15/16"	13/16"
S302	COE M-62 Jet	10	A	1-1/2"	Plain Bore	1-1/4"	1-1/8"
S313	Moore RD-130	10	A	1-1/2"	1/4"	15/16"	13/16"
S312	Moore RD-2S	10	A	1-1/2"	1/4"	1-1/4"	1-1/8"
S323	-	10	A	1-1/2"	3/8"	1-1/4"	1-1/8"
S111	Moore RD-77, COE 8216	10	B	1"	1/4"	2-1/4"	1-1/8"
S201	Moore	10	B	1-1/4"	Plain Bore	2-1/4"	1-1/8"
S211	-	10	B	1-1/4"	1/4"	2-1/4"	1-1/8"
S222	Moore RD-3, COE 389	10	B	1-1/4"	3/8"	2-1/4"	1-1/8"
S301	Moore, Prentice	10	B	1-1/2"	Plain Bore	2-1/4"	1-1/8"
S311	Moore, Prentice	10	B	1-1/2"	1/4"	2-1/4"	1-1/8"
S311-2K	Moore, Prentice	10	B	1-1/2"	1/4", 3/8"	2-1/4"	1-1/8"
S321	COE PC018139	10	B	1-1/2"	3/8"	2-1/4"	1-1/8"
S322	Westmill, COE PC018139	10	B	1-1/2"	3/8"	1-7/8"	1-1/8"
S322-2K	Westmill, COE PC018139	10	B	1-1/2"	3/8"	1-7/8"	1-1/8"
S324	Westmill, COE M72 , PC079387 (Cooling Section)	10	B	1-1/2"	3/8"	1-3/4"	1"
S742	Babcock	10	B	20 mm	-	38 mm	26 mm
S101	Raute Wood 3R708513	12	B	1"	1/4"	1-29/32"	1"
S101-M	Raute Wood 3R403462	12	B	25 mm	8 mm	50 mm	25 mm



Standard (B-Hub)



Hubless (A-Style)



Feed Section Flat Star Gear S213

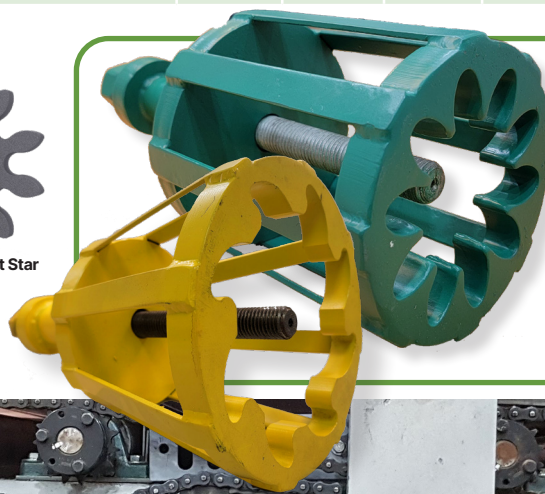

**WE STOCK SPROCKET & STAR GEAR PULLERS**

**Safe & Easy Removal**

Please contact our sales team for more information.



CONVEYOR COMPONENTS

ROLL TUBES & ASSEMBLIES

MAJOR COMPONENTS

DRYER DOORS

GENERAL COMPONENTS

WESTMILL EQUIPMENT

WESTMILL PART NO.	CROSS REFERENCE	TEETH	HUB STYLE	BORE	KEY WAY	LENGTH THRU BORE	TOOTH WIDTH
-------------------	-----------------	-------	-----------	------	---------	------------------	-------------

### HOOK TOOTH & REVERSING (81X CHAIN)

SP222	COE-389 Moore RD-3	7	C	1-1/2"	1/4"	2-1/4"	1"
SP321	COE-389 Moore RD-3	7	C	1-1/2"	3/8"	2-1/4"	1"
SP111	MRJ COE 8216 Moore RD-77	8	C	1"	1/4"	2-1/4"	1"
SP211	COE 8216 Moore RD-77	8	C	1-1/4"	1/4"	2-1/4"	1"
SP211-2K	COE 8216 Moore RD-77 PB-015261	8	C	1-1/4"	1/4" & 3/8"	2-1/4"	1"
SP221	COE 8216 Moore RD-77 PB-015261	8	C	1-1/4"	3/8"	2-1/4"	1"
SP223	COE 8216 Moore RD-77	8	C	1-1/2"	1/4"	2-1/4"	1"
SP224	Prentice C-9 Reversing Sprocket	8	C	1-1/2"	1/4"	2-1/4"	1"
SP224-2K	Prentice C-9 Reversing	8	C	1-1/2"	1/4" & 3/8"	2-1/4"	1"
SP226	Split Sprocket NW-22S	8	C	1-1/4"	-	2-3/8"	1"
SP227	-	8	C	1-1/4"	-	2-1/4"	1"
SP324	NW-J22C	8	C	1-1/2"	3/8"	2-5/8"	1"
SP322	COE 8216 Moore RD-77 Narrow Tooth Width	8	C	1-1/2"	3/8"	2"	1/2"
SP323	Westmill, COE PC018140 (M72/M62)	8	C	1-1/2"	3/8"	2-1/4"	1"
SP323-2K	Westmill, COE M72, M62	8	C	1-1/2"	1/4" & 3/8"	2-1/4"	1"
SP323-H	COE PC018140 (M72/M62)	8	C	1-1/2"	3/8"	2-1/4"	1"
SP326	Westmill, COE Split Sprocket	8	C	1-1/2"	-	2-3/8"	1"

### DRYER DRIVE TOWER SPROCKETS (81X CHAIN)

SP730	RD-76 Moore NW-86	8	B	2-3/16"	1/2"	3"	7/8"
SP840	NW-87 COE	8	C	2-3/16"	5/8"	3"	7/8"

### DRYER DRIVE TOWER SPROCKETS (RC80 CHAIN)

SP171	Babcock	13	B	20 mm	-	27.5 mm	15 mm
-------	---------	----	---	-------	---	---------	-------



RAUTE WOOD  
RAU-013



REVERSING HOOK  
TOOTH SP224



HOOK TOOTH  
SPROCKET SP323



HOOK TOOTH  
SPROCKET SP323-H



HOOK TOOTH SPLIT  
SPROCKET SP326



HOOK TOOTH  
SPROCKET SP227



DRIVE SPROCKET  
SP840

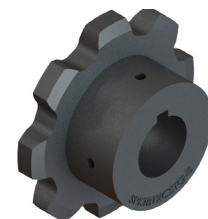

DRIVE SPROCKET  
SP730

HUB STYLE	DESCRIPTION
A HUB	No Flange
B HUB	Flange on one side
C HUB	Flange on both sides

# SPROCKETS

CONVEYOR COMPONENTS

ROLL TUBES & ASSEMBLIES

MAJOR COMPONENTS

DRYER DOORS

GENERAL COMPONENTS

WESTMILL EQUIPMENT

WESTMILL PART NO.	CROSS REFERENCE	TEETH	HUB STYLE	BORE	KEY WAY	LENGTH THRU BORE	TOOTH WIDTH
-------------------	-----------------	-------	-----------	------	---------	------------------	-------------

## DRYER IDLER SPROCKETS (81X)

SB400	RD-175A	8	B	1.775" Ball Bearing	-	3"	7/8"
SZ600	RD-175	8	B	2-3/16" Bronze Bushing	-	3"	7/8"
SZ221	COE	8	C	1-1/4" Bronze Bushing	-	3"	7/8"

## RAUTE WOOD / DURAND-RAUTE (RC100)

RAU-011	514-6017 Dryer Roll Sprocket	17	B	1"	1/4"	1-1/2"	0.692"
RAU-013	Raute Metric-3 Sheet Dryer	15	B	25mm	8mm	1-1/2"	18mm

## DRIVE & IDLER (RC50)

WEST- 109	50B10 Idler Sprocket	10	B	3/4" Oilite Bushing	-	1"	0.343"
SP212	Drive Sprocket	15	B	1-1/2"	1/4"	1"	0.343"
SP213	Drive Sprocket	16	B	1"	1/4"	1"	0.343"

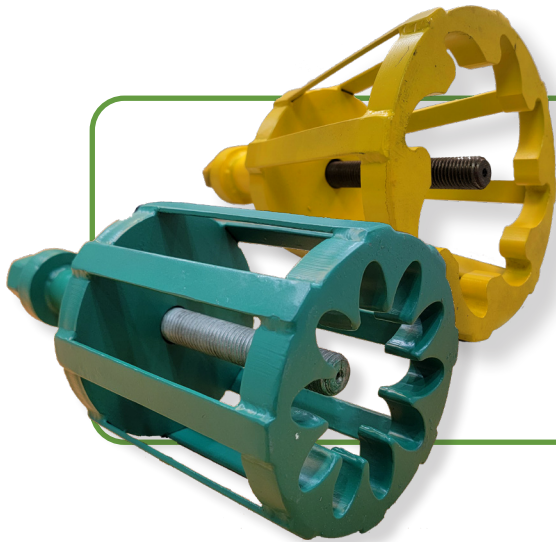

## WE STOCK SPROCKET & STAR GEAR PULLERS

### Safe & Easy Removal

Please contact our sales team for more information.

HUB STYLE	DESCRIPTION
A HUB	No Flange
B HUB	Flange on one side
C HUB	Flange on both sides

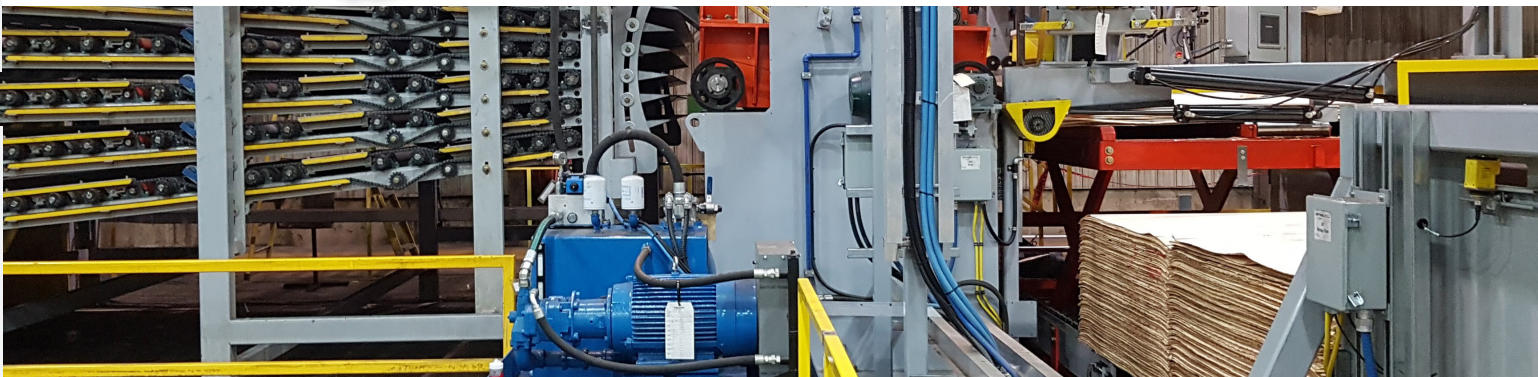

## CHAIN HOLD DOWNS

Chain hold downs keep your dryer chain engaged to the roll sprockets and support the chain among its return path. Our chain hold downs are made from rugged cast iron.

Westmill also supplies mounting brackets for the chain hold downs, if required.

WESTMILL PART NO.	CROSS REFERENCE	PART NAME
<b>CHAIN HOLD DOWNS</b>		
C001	Moore RD-7	Chain Return Shoe
C002	Moore RD-7C	Return Shoe Mounting Clip
C003	COE 8213	Long Chain Hold down & Return
C004	COE 7907, COE 10979	Short Chain Hold down and Return for COE M-62
C005	COE 8228	Top Chain Hold down - Long
C006	Prentice C30	Prentice Chain Hold Down - bolts to m62 Rabbit Ear
C007	Westmill, COE PC065295	Chain Hold Down and return for COE M72
C012	Moore RD-145 COE 619-2040-00	Moore Dryer Chain Return Shoe
C017	RD-158	Chain Bridge

<b>CHAIN WINDOWS</b>		
C008	Prentice C33	Single Chain Window (Prentice)
C014	Prentice C34	Double Chain Window (Prentice)
C009	PA033855, CP010866	Double Chain Window
C010	PB025130, CP010867	Single Chain Window (out)
C011	PB025131, CP010868	Single Chain Window (in)

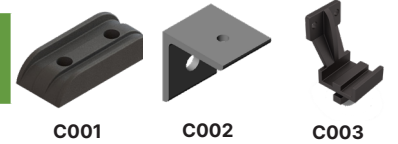

CONVEYOR COMPONENTS

ROLL TUBES & ASSEMBLIES

MAJOR COMPONENTS

DRYER DOORS

GENERAL COMPONENTS

WESTMILL EQUIPMENT

## DRYER CHAIN (81X)

Westmill supplies various styles of 81X veneer dryer chain. 81X chain is also used on other material conveying machinery.

### We offer several sizes of chain:

- 81X chain: Straight side bar, bushed roller chain
- 81X-HD Chain: Heavy duty, straight side bar, bushed roller chain
- 81X-XHD Chain: Extra heavy duty, straight side bar, bushed roller chain
- Connecting links for all of the above chains

CHAIN	DUTY LEVEL	LINK
WEST-81X	81X, Standard Duty	WEST-81XXSD
WEST-81XHD	81X, Heavy Duty	WEST-81XXHD
WEST-81XKD	81X, Kiln Duty	WEST-81XXKD

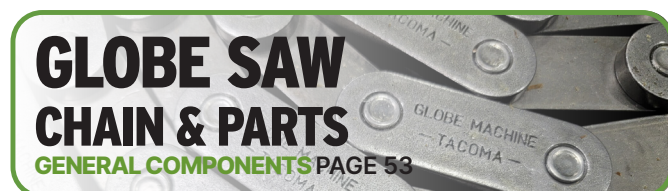

# GUDGEONS

CONVEYOR  
COMPONENTS

ROLL TUBES &  
ASSEMBLIES

MAJOR  
COMPONENTS

DRYER DOORS

GENERAL  
COMPONENTS

WESTMILL  
EQUIPMENT

WESTMILL PART NO.	DIAMETER	LENGTH	KEY SIZE	CONSTRUCTION	NOTES
<b>GUDGEON ONE WOODRUFF KEY</b>   Note: Key #808 is 1/4" wide x 1" long   Key #1210 is 3/8" wide x 1-1/4" long					
G211	1-1/4"	3"	#808	Cast Iron	Infeed
G223	1-1/4"	3"	#1210	Cast Iron	COE Dryer
G212	1-1/4"	3-1/2"	#808	Cast Iron	Infeed
G225	1-1/4"	3-3/4"	#1210	Cast Iron	Infeed Gudgeon for M72
G224	1-1/4"	4"	#1210	Cast Steel	Infeed Gudgeon for M72
G213	1-1/4"	5"	#808	Cast Iron	Infeed Drive
G222	1-1/4"	5"	#1210	Cast Iron	COE
G221	1-1/2"	4-3/8"	#1210	Cast Iron	COE M62
G321	1-1/2"	4-3/8"	#1210	Cast Iron	Westmill, COE M72
G311	1-1/2"	5"	#808	Cast Iron	Moore & Prentice
G322	1-1/2"	5"	#1210	Cast Iron	COE
G327	1-1/2"	5-1/2"	#1210	Cast Iron	-
<b>GUDGEON TWO WOODRUFF KEY</b>   Note: Key #808 is 1/4" wide x 1" long   Key #1210 is 3/8" wide x 1-1/4" long					
G215	1-1/4"	5"	#808	Cast Iron	Flattening Roll
G326	1-1/2"	5"	#808	Cast Iron	Cross-Over Drive
G325	1-1/2"	6-1/2"	#1210	Cast Steel	Cross-Over Drive
G323	1-1/2"	7-3/8"	#1210	Cast Steel	COE M62
G324	1-1/2"	7-3/4"	#1210	Cast Steel	Westmill, COE M72
<b>GUDGEON SNAP RING GROOVE</b>					
G101-M	25mm	2-1/2"	NA	Cast Iron	Raute Top & Bottom, idler side
G101	1"	2-5/8"	NA	Cast Steel	Raute Top & Bottom, idler side
G302	1-1/2"	2-3/4"	NA	Cast Iron	Westmill, COE M62/M72



WESTMILL PART NO.	DIAMETER	LENGTH	KEY SIZE	CONSTRUCTION	NOTES
-------------------	----------	--------	----------	--------------	-------

### GUDGEON STRAIGHT KEYWAY

G111-M	25mm	3-15/16"	8mm	Cast Steel	Raute Top Drive Side
G112-M	25mm	5-13/16"	8mm	Cast Steel	Raute Bottom Drive Side
G111	1"	4-1/8"	1/4" x 2-1/4"	Cast Steel	Raute Top Drive Side
G112	1"	6"	1/4" x 4"	Cast Steel	Raute Bottom Drive Side
G214	1-1/4"	5"	1/4" x 3"	Cast Steel	Infeed
G216	1-1/4"	6-1/4"	1/4" x 2"	Cast Steel	COE Infeed Lower Roller
G217	1-1/4"	6-3/4"	1/4" x 4"	Cast Steel	Infeed
G312	1-1/2"	5"	1/4" x 3"	Cast Iron	COE

### GUDGEON NO KEY

G201	1-1/4"	2-1/8"	NA	Cast Iron	Infeed
G203	1-1/4"	4"	NA	Cast Steel	Infeed Gudgeon for M72
G202	1-1/4"	5"	NA	Cast Iron	Infeed
G301	1-1/2"	2"	NA	Cast Iron	Westmill, COE M62/M72 Top, Moore
G303	1-1/2"	5"	NA	Cast Iron	Moore Top
G304	1-1/2"	6-1/2"	NA	Cast Iron	-



ONE WOODRUFF KEY  
G211

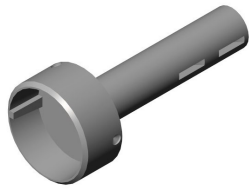

TWO WOODRUFF KEY  
G324



SNAP RING GROOVE  
G302



STRAIGHT KEYWAY  
G312

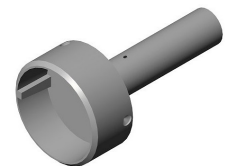

NO KEY  
G202

## CUSTOM GUDGEONS

Westmill can supply any custom gudgeon design required.

The gudgeon shaft is connected to the bell housing by welding. Our bell housings are designed to fit roll tubes 3-3/4" outer diameter x 0.125" wall. We can also assemble the entire roll assembly before shipping.



# COULDN'T FIND THE PART YOU NEED?

WE CAN MAKE IT FOR YOU



**CONTACT OUR SALES TEAM TODAY!**



## DRYER ROLL TUBING

Westmill supplies roll tubes for all makes and models of veneer dryers, infeeds, outfeeds, and sheet-handling conveyors.

We can supply any diameter, wall thickness, and length you need. We are likely to have your tubes in stock and available for you in a week or less.



WESTMILL PART NO.	OUTER DIAMETER	WALL THICKNESS	LENGTH
WEST-64	2-1/4"	0.125"	15'
WEST-165	3"	0.125"	9'-5 1/4"
WEST-315	3-3/4"	0.125"	14'-6"
WEST-304	3-3/4"	0.125"	15'
WEST-305	3-3/4"	0.125"	15'-6"
WEST-167	4"	0.125"	9'-6"
RAU-009	4"	0.125"	15'-9"

\* For custom lengths, please contact our sales team

## WHY IS IT SO IMPORTANT TO HAVE STRAIGHT DRYER ROLLS?

The standard tolerance for Run-out of a 180" long dryer roll from a North American steel mill can be upwards of 0.250 - 0.375, leading to veneer plug-up's and sheet tracking issues. WESTMILL is the only dryer manufacturer that straightens every roll assembly to within 1/16" (0.063) before sending them to our customers.

## STANDARD & CUSTOM PRE-ASSEMBLED ROLLERS

Avoid misaligned tubes and gudgeons that cause veneer tracking issues and premature drive-side wear by using Westmill professionally pre-assembled roll tubes and gudgeons.

- Eliminate time-consuming roll assembly
- Gudgeons are hydraulically press-fit for accuracy
- Welded or Dimple locked to prevent slippage
- Roll assemblies are hydraulically straightened after assembly
- Available for all dryer makes and models
- An economic solution



CONVEYOR COMPONENTS

ROLL TUBES & ASSEMBLIES

MAJOR COMPONENTS

DRYER DOORS

GENERAL COMPONENTS

WESTMILL EQUIPMENT

# ROLL SET

## WESTMILL JET

SET AS SEEN BELOW: R01-0024-02

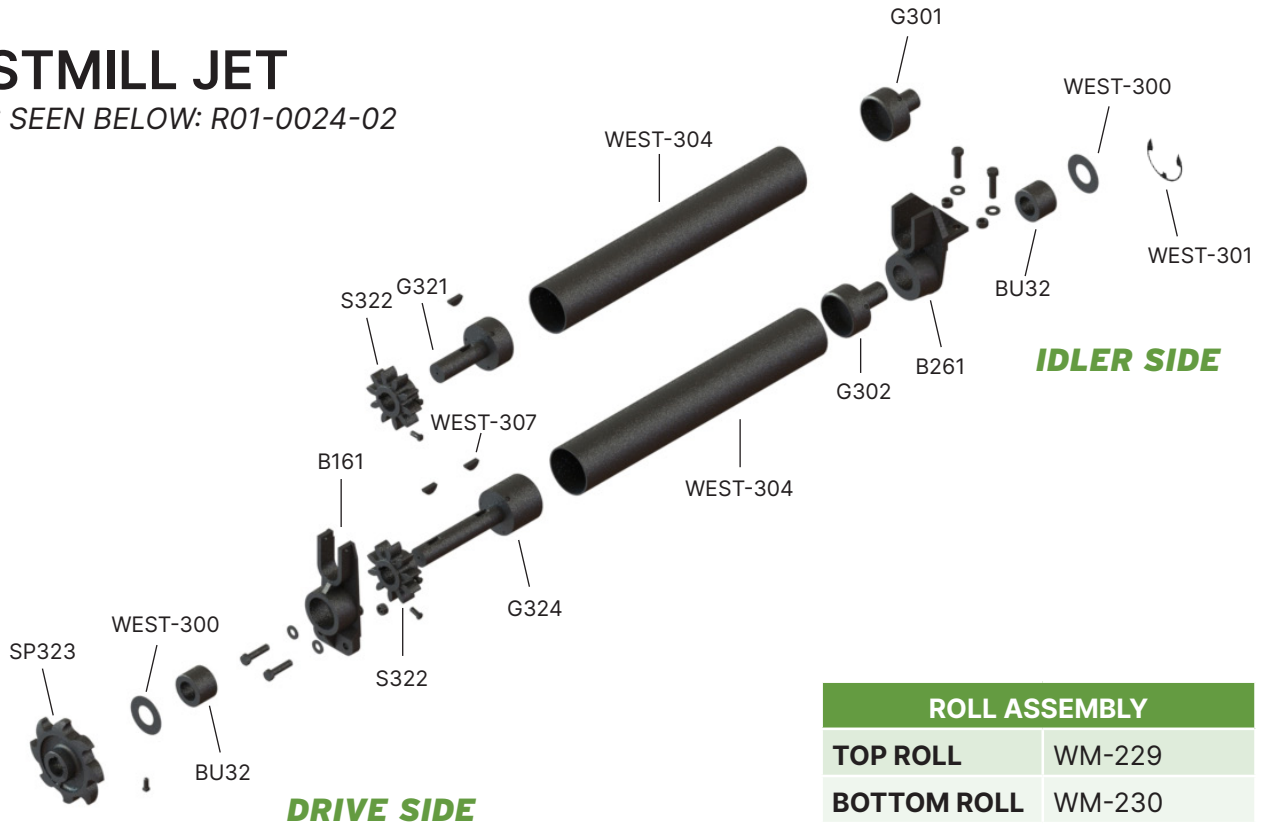

ROLL ASSEMBLY	
TOP ROLL	WM-229
BOTTOM ROLL	WM-230

WESTMILL PART NO.	QUANTITY	DESCRIPTION
WEST-304	2	Roll Tube, 3-3/4" OD x 0.125 Wall x 15' 0" Lg
G321	1	Gudgeon, 1-1/2" x 4-3/8" Lg, 3/8" Woodruff Keyway
G301	1	Gudgeon, 1-1/2" x 2" Lg
G302	1	Gudgeon, 1-1/2" x 2-3/4" Lg, w/ Snap Ring Groove
G324	1	Gudgeon, 1-1/2" x 7-3/4" Lg, 2x 3/8" Woodruff Keyway
B261	1	Bearing Housing, Idler Side
B161	1	Bearing Housing, Drive Side, Closed Back
BU32	2	Bearing, Graphite, 1-1/2" ID x 2-1/2" OD x 1-3/4" Lg
SP323	1	Sprocket, 8-Tooth, 1-1/2" Bore x 2-1/4" LTB, 3/8" Keyway
S322	2	Star Gear, 10-Tooth, 1-1/2" Bore, 1-7/8" LTB, 3/8" Keyway
WEST-300	2	Washer, 1-9/16" (1-1/2" Nom) ID x 3" OD x 1/16" Thk
WEST-301	1	Snap Ring, 1-1/2" (1.375") "E"
WEST-307	3	Woodruff Key, 3/8" x 1-1/4", Type E, #1210
WEST-302	3	Set Screw, Square Head, 3/8"-16 UNC x 3/4" Lg
DH923	4	Nut, Hex, 1/2"-13 UNC
WEST-225	4	Capscrew, 1/2"-13 UNC x 1-3/4" Lg
WEST-226	4	Washer, Narrow, 1/2" Dia, SAE

CONVEYOR COMPONENTS

ROLL TUBES & ASSEMBLIES

MAJOR COMPONENTS

DRYER DOORS

GENERAL COMPONENTS

WESTMILL EQUIPMENT

## COE M-62 JET

SET AS SEEN BELOW: R01-0038-01

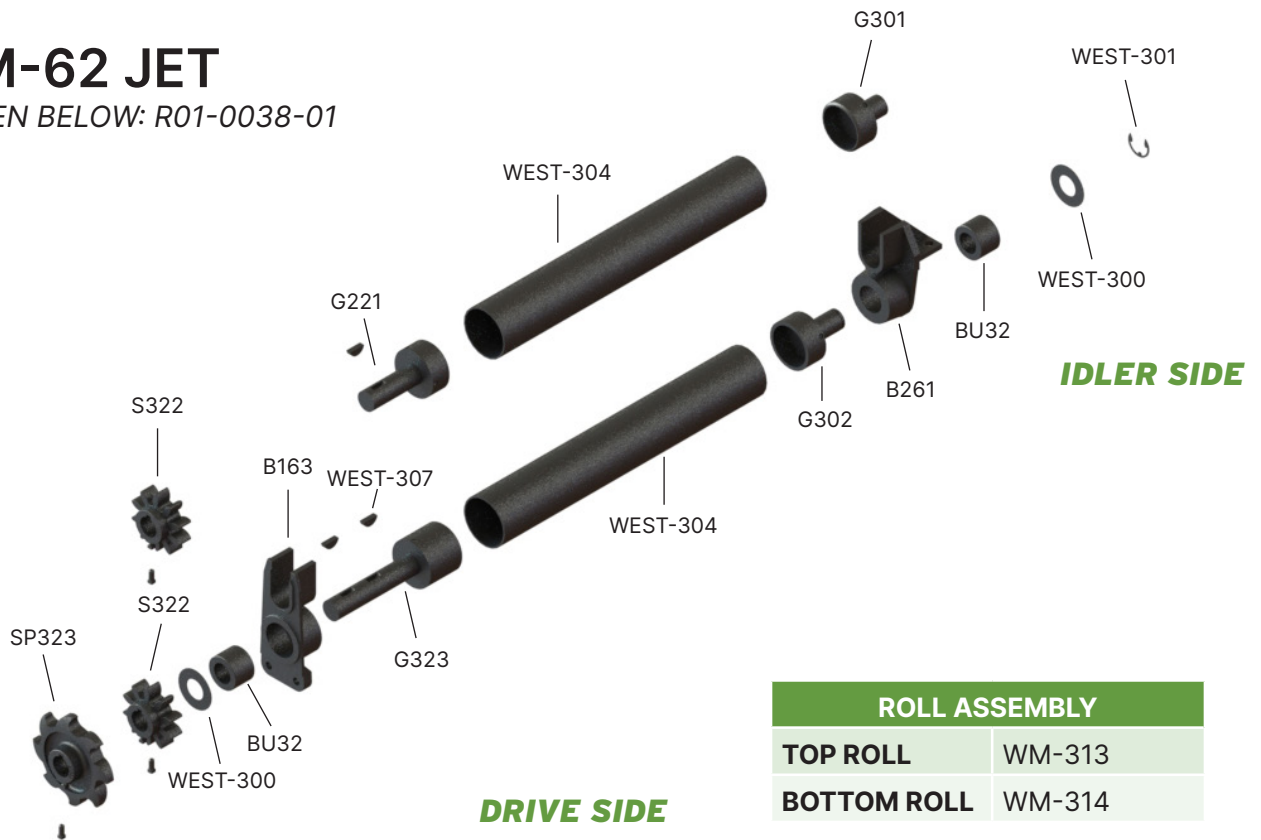

ROLL ASSEMBLY	
TOP ROLL	WM-313
BOTTOM ROLL	WM-314

WESTMILL PART NO.	QUANTITY	CROSS REFERENCE	DESCRIPTION
WEST-304	2	VM011288	Roll Tube, 3-3/4" OD x 0.125 Wall x 15' 0" Lg
G221	1	-	Gudgeon, 1-1/2" x 4-3/8" Lg, 3/8" Woodruff Keyway
G301	1	-	Gudgeon, 1-1/2" x 2" Lg
G302	1	PC- 010091-B	Gudgeon, 1-1/2" x 2-3/4" Lg, w/ Snap Ring Groove
G323	1	-	Gudgeon, 1-1/2" x 7-3/4" Lg, 2x 3/8" Woodruff Keyway
B261	1	COE 10497	Bearing Housing, Idler Side
B163	1	COE 10499	Bearing Housing, Drive Side, Closed Back
BU32	2	-	Bearing, Graphite, 1-1/2" ID x 2-1/2" OD x 1-3/4" Lg
SP323	1	PC-018140	Sprocket, 8-Tooth, 1-1/2" Bore x 2-1/4" LTB, 3/8" Keyway
S322	2	PC-045141	Star Gear, 10-Tooth, 1-1/2" Bore, 1-7/8" LTB, 3/8" Keyway
WEST-300	2	VM010601	Washer, 1-9/16" (1-1/2" Nom) ID x 3" OD x 1/16" Thk
WEST-301	1	-	Snap Ring, 1-1/2" (1.375") "E"
WEST-307	3	VM010120	Woodruff Key, 3/8" x 1-1/4", Type E, #1210
WEST-302	3	-	Set Screw, Square Head, 3/8"-16 UNC x 3/4" Lg
DH923	2	-	Nut, Hex, 1/2"-13 UNC
WEST-225	2	-	Capscrew, 1/2"-13 UNC x 1-3/4" Lg
WEST-226	2	-	Washer, Narrow, 1/2" Dia, SAE

CONVEYOR COMPONENTS

ROLL TUBES & ASSEMBLIES

MAJOR COMPONENTS

DRYER DOORS

GENERAL COMPONENTS

WESTMILL EQUIPMENT

# ROLL SET

## COE M-72 JET & USNR-208

SET AS SEEN BELOW: R01-0024-02



ROLL ASSEMBLY	
TOP ROLL	WM-229
BOTTOM ROLL	WM-230

WESTMILL PART NO.	QTY.	CROSS REFERENCE	DESCRIPTION
WEST-304	2	VM011288	Roll Tube 3-3/4" OD x 15' LG
G321	1	COE M-72, PC-010091A	Gudgeon 1-1/2" D x 4-3/8" LG stem
G301	1	COE M-62/M-72	Gudgeon 1-1/2" D x 2" LG stem
G302	1	COE M-62/M-72, PC-010091-B	Gudgeon (Snap Ring Groove)
G324	1	COE M-72	Gudgeon 1-1/2" D x 7-3/4" LG stem
B261	1	COE M-62/M-72	Bearing Housing, Idler Side,
B161	1	COE 8212	Bearing Housing, Drive Side
BU32	2	PC06609, COE, Westmill	Bearing, Graphite, 1-1/2" ID x 2-1/2" OD x 1-3/4" Lg
SP323	1	COE, PC-018140	8-Tooth, Hook Sprocket, 81X
S322	2	COE 8216, PC-045141	10-Tooth, 1-1/2" Bore, 1-7/8" LTB, 3/8" Keyway
WEST-300	2	VM-010601	1-9/16" D Gudgeon Washer
WEST-301	1	VM-010108	Gudgeon Snap Ring, 1-1/2" (1.375") 'E'
WEST-307	3	VM-010120	#1210 3/8" Woodruff Key
WEST-302	3	-	Square Head Set Screw 3/8" UNC x 3/4"
DH923	4	-	Nut, Hex, 1-1/2" - 13 UNC, Gr.8
WEST-225	4	-	Cap Screw, Hex Head, 1/2" - 13 UNC x 1-3/4", Lg, Gr.5
WEST-226	4	-	Washer, Flat, Narrow, 1/2" Dia, Gr.5

CONVEYOR COMPONENTS

ROLL TUBES & ASSEMBLIES

MAJOR COMPONENTS

DRYER DOORS

GENERAL COMPONENTS

WESTMILL EQUIPMENT

## RAUTE WOOD / DURAND RAUTE NORTH AMERICAN-BUILT JET DRYER (e.g. 4-DECK JET) (PRE-2000) SET AS SEEN BELOW: R01-0134-01

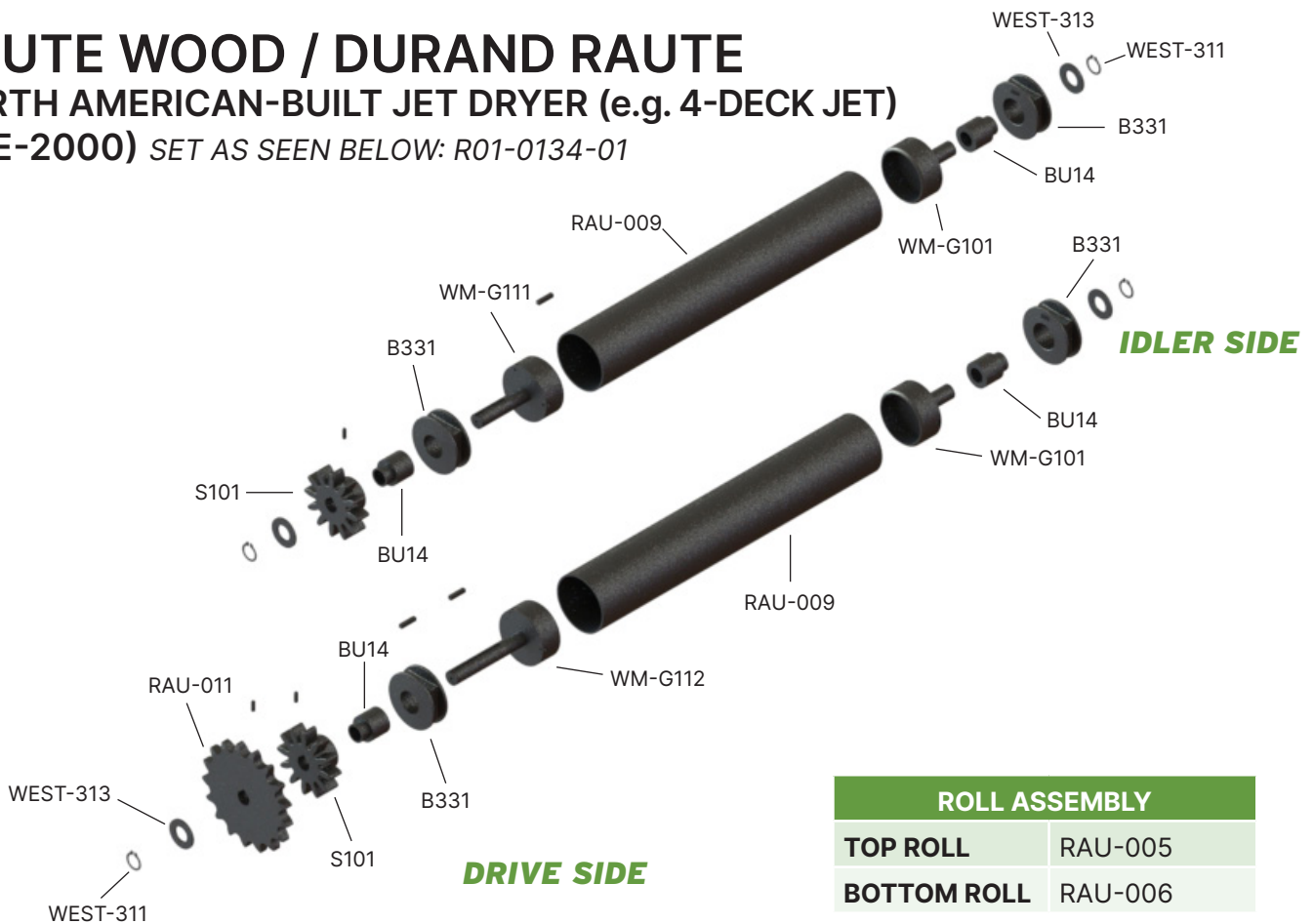

ROLL ASSEMBLY	
TOP ROLL	RAU-005
BOTTOM ROLL	RAU-006

WESTMILL PART NO.	QTY.	CROSS REFERENCE	DESCRIPTION
RAU-009	2	Raute Wood	Roll Tube, 4" OD x 0.125" Wall x 189" Lg
G101	2	Raute Wood	Gudgeon, Idler, 2-9/16", Cast Steel
G111	1	Raute Wood	Gudgeon, Drive, Top, 1" Dia x 4-1/8" Stem, w/Square Keyway & Snap Ring
G112	1	Raute Wood	Gudgeon, Drive, Bottom, 1" Dia x 6" Stem, w/ square Keyway & Snap Ring
B331	4	Raute Wood 4R708667	Bearing Housing
BU14	4	Raute Wood	Bushing, Teflon, 1" ID x 1-3/4" OD x 2-1/8" Lg, w/ Step
S101	2	Raute Wood	Star Gear, 12-Tooth, B-Hub, 1" Bore, 1-7/8" LTB, 1/4" Keyway, Cast Iron
RAU-011	1	Raute Wood	Sprocket, Raute, 17-Tooth, 1" Bore x 1/4" Key
WEST-420	3	-	Key, 1/4" Square x 1-1/4" Long, A36
WEST-412	3	-	Set screw 1/4" UNC x 3/4" Long, Cup Pt.
WEST-311	4	-	Snap ring Tru-Arc 5100-100
WEST-313	4	-	Washer, Flat, 1-1/16" ID x 2" OD x 1/8" THK

CONVEYOR COMPONENTS

ROLL TUBES & ASSEMBLIES

MAJOR COMPONENTS

DRYER DOORS

GENERAL COMPONENTS

WESTMILL EQUIPMENT

# ROLL SET

## RAUTE WOOD

FINLAND-BUILT JET DRYER (e.g. 6-DECK JET)  
(2000 & NEWER) SET AS SEEN BELOW: R01-0134-M

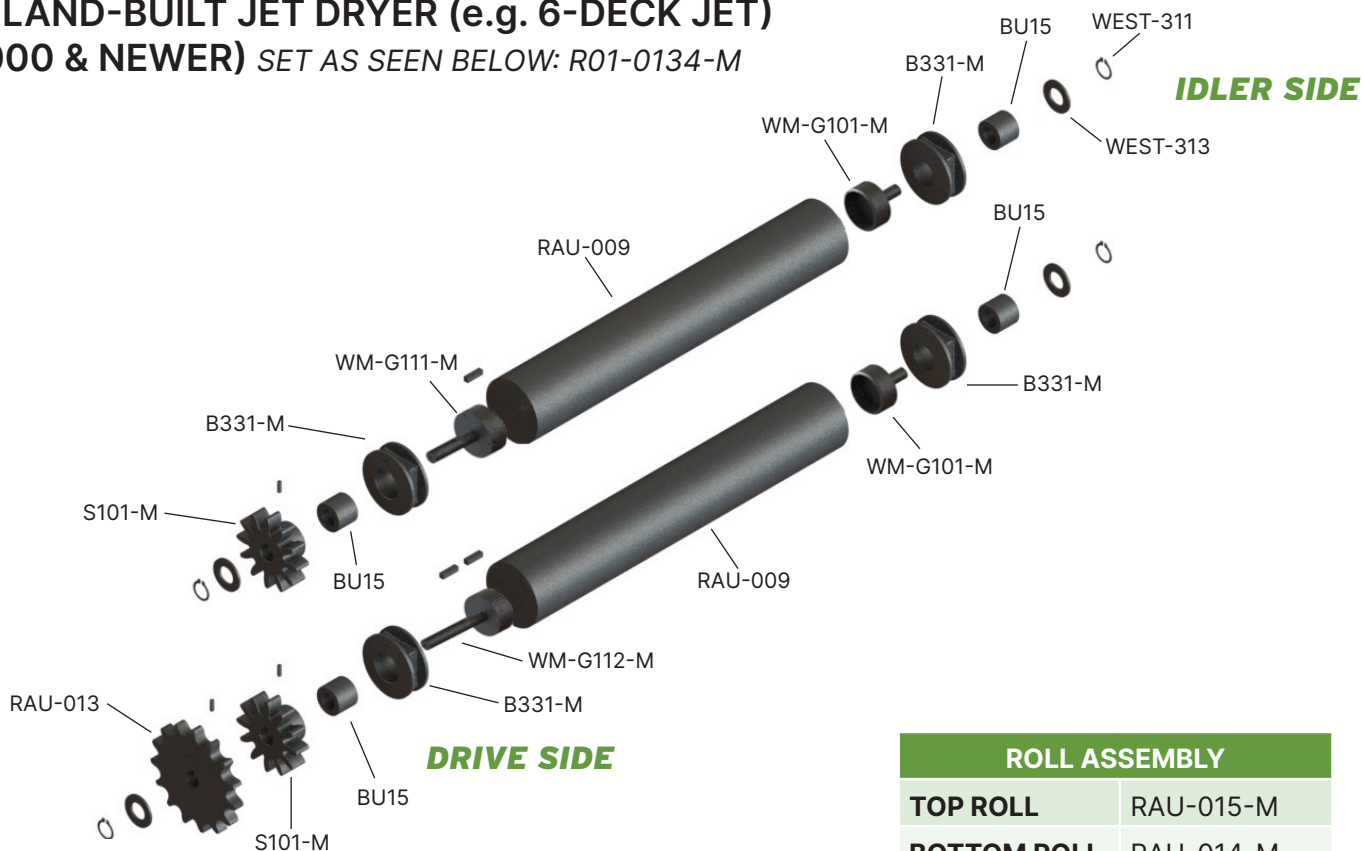

ROLL ASSEMBLY	
TOP ROLL	RAU-015-M
BOTTOM ROLL	RAU-014-M

WESTMILL PART NO.	QTY.	CROSS REFERENCE	DESCRIPTION
RAU-009	2	Raute Wood	Roll Tube, 4" OD x 0.125" Wall x 189" Lg
G101-M	2	-	Gudgeon, Idler, 25mm Dia x 64mm Stem
G111-M	1	-	Gudgeon, Drive, 25mm OD x 100mm Stem, w/ Keyway & Snap Ring
G112-M	1	-	Gudgeon, Drive, 25mm OD x 148mm Stem, w/ Keyway & Snap Ring
B331-M	4	Raute Wood 4R504306KK	Bearing Housing, Metric
BU15	4	Raute Wood	Bushing, Teflon, 25mm ID x 45mm OD x 38mm Lg
S101-M	2	Raute Wood 3R708513	Star Gear, 12-Tooth, B-Hub, 25mm Bore, 50mm LTB, 8mm Keyway
RAU-013	1	Raute Wood 4R900147	Sprocket, 15-Tooth, 25mm Bore
WEST-830	3	-	Key, 8 mm x 30 mm Lg, Square
WEST-412	2	-	Set screw 1/4" UNC x 3/4" Long, Cup Pt.
WEST-311	4	-	Snap ring Tru-Arc 5100-100
WEST-313	4	-	Washer, Flat, 1-1/16" ID x 2" OD x 1/8" Thk.

CONVEYOR COMPONENTS

ROLL TUBES & ASSEMBLIES

MAJOR COMPONENTS

DRYER DOORS

GENERAL COMPONENTS

WESTMILL EQUIPMENT

## COE LONGITUDINAL 15" VERTICAL DECK SPACING

SET AS SEEN BELOW: R01-0103-01

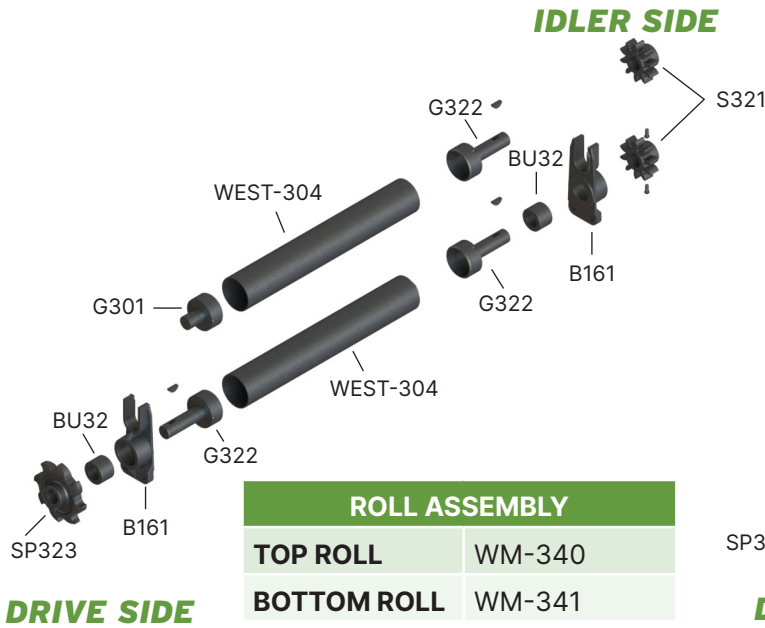

ROLL ASSEMBLY	
TOP ROLL	WM-340
BOTTOM ROLL	WM-341

**DRIVE SIDE**

WESTMILL PART NO.	QTY	CROSS REF.	DESCRIPTION
WEST-304	2	VM011288	Roll Tube, 3-3/4" OD x 0.125 Wall x 15' 0" Lg
G301	1	-	Gudgeon, 1-1/2" x 2" Lg
G322	3	-	Gudgeon, 1-1/2" x 5" Lg, 3/8" Woodruff KY
B161	2	COE 8212	Bearing Housing, Drive Side, Closed Back
BU32	2	PC-066095	Bearing, Graphite, 1-1/2" ID x 2-1/2" OD x 1-3/4" Lg
SP323	1	PC-018140	Sprocket, 8-Tooth, 1-1/2" Bore x 2-1/4" LTB, 3/8" KY
S321	2	PC-018139	Star Gear, 10-Tooth, 1-1/2" Bore, 2-1/4" LTB, 3/8" Keyway
WEST-307	3	VM010120	Woodruff Key, 3/8" x 1-1/4", Type E, #1210
WEST-302	3	-	Set Screw, Square Head, 3/8"-16 UNC x 3/4" Lg

## COE LONGITUDINAL 15" VERTICAL DECK SPACING (AT LEFT OF DOOR POST)

SET AS SEEN BELOW: R01-0104-01

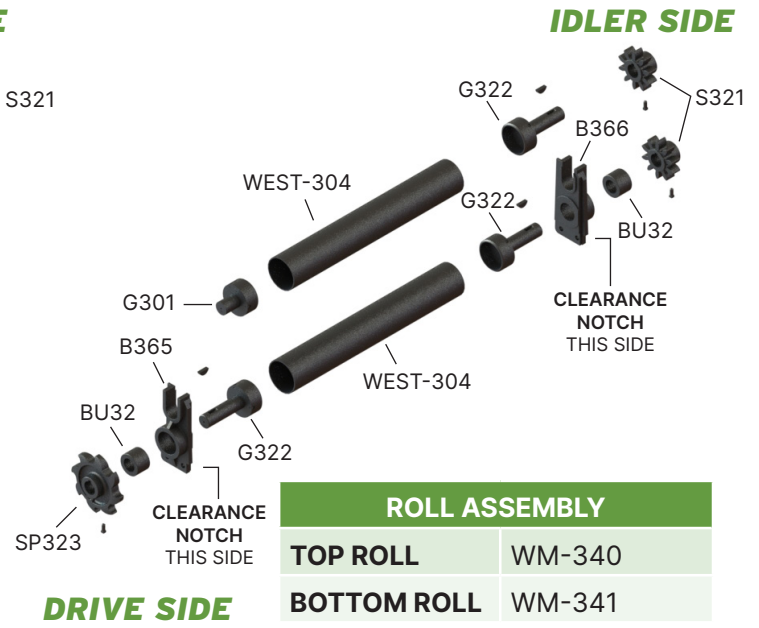

ROLL ASSEMBLY	
TOP ROLL	WM-340
BOTTOM ROLL	WM-341

**DRIVE SIDE**

WESTMILL PART NO.	QTY	CROSS REF.	DESCRIPTION
WEST-304	2	VM011288	Roll Tube, 3-3/4" OD x 0.125 Wall x 15' 0" Lg
G301	1	-	Gudgeon, 1-1/2" x 2" Lg
G322	3	-	Gudgeon, 1-1/2" x 5" Lg, 3/8" Woodruff KY
B366	1	PB-016048L	Bearing Hanger, 8282, Notched LH
B365	1	PB-016048R	Bearing Hanger, 8281, Notched, RH
BU32	2	PC-066095	Bearing, Graphite, 1-1/2" ID x 2-1/2" OD x 1-3/4" Lg
SP323	1	PC-018140	Sprocket, 8-Tooth, 1-1/2" Bore x 2-1/4" LTB, 3/8" KY
S321	2	PC-018139	Star Gear, 10-Tooth, 1-1/2" Bore, 2-1/4" LTB, 3/8" Keyway
WEST-307	3	VM010120	Woodruff Key, 3/8" x 1-1/4", Type E, #1210
WEST-302	3	-	Set Screw, Square Head, 3/8"-16 UNC x 3/4" Lg

CONVEYOR COMPONENTS

ROLL TUBES & ASSEMBLIES

MAJOR COMPONENTS

DRYER DOORS

GENERAL COMPONENTS

WESTMILL EQUIPMENT

# ROLL SET

## COE LONGITUDINAL 15" VERTICAL DECK SPACING (AT RIGHT OF DOOR POST) SET AS SEEN BELOW: R01-0104-01

## MOORE JET STANDARD (PRE-1970S)

SET AS SEEN BELOW: R01-0108-01

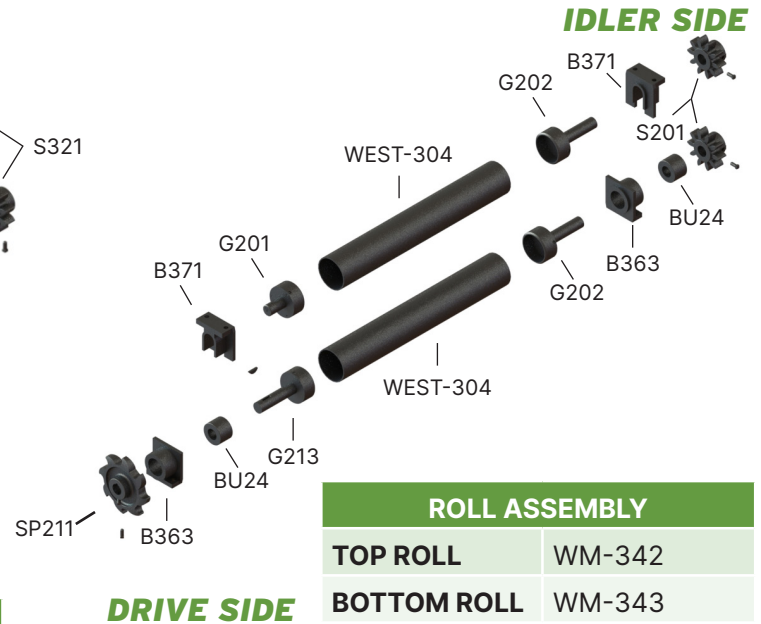
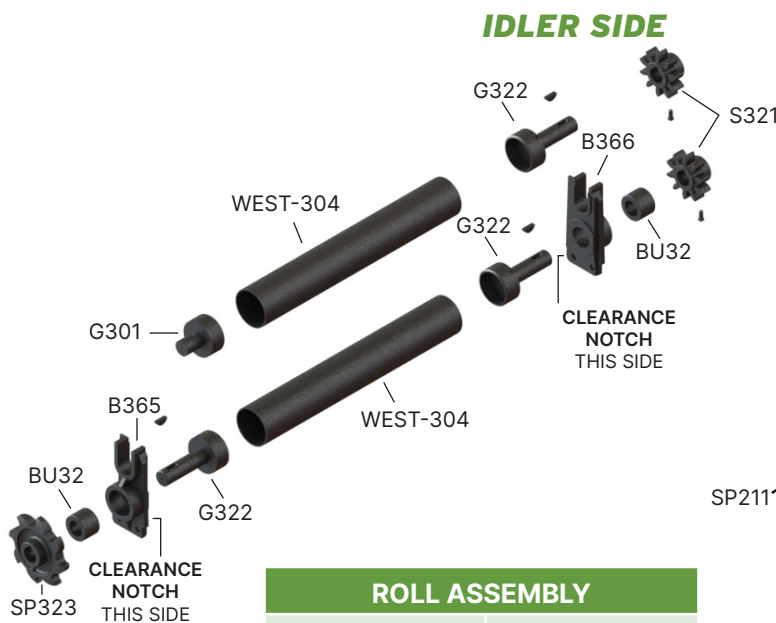

ROLL ASSEMBLY	
TOP ROLL	WM-340
BOTTOM ROLL	WM-341

ROLL ASSEMBLY	
TOP ROLL	WM-342
BOTTOM ROLL	WM-343

WESTMILL PART NO.	QTY	CROSS REF.	DESCRIPTION
WEST-304	2	VM011288	Roll Tube, 3-3/4" OD x 0.125 Wall x 15' 0" Lg
G301	1	-	Gudgeon, 1-1/2" x 2" Lg
G322	3	-	Gudgeon, 1-1/2" x 5" Lg, 3/8" Woodruff KY
B366	1	PB-016048L	Bearing Hanger, 8282, Notched LH
B365	1	PB-016048R	Bearing Hanger, 8281, Notched, RH
BU32	2	PC-066095	Bearing, Graphite, 1-1/2" ID x 2-1/2" OD x 1-3/4" Lg
SP323	1	PC-018140	Sprocket, 8-Tooth, 1-1/2" Bore x 2-1/4" LTB, 3/8" KY
S321	2	PC-018139	Star Gear, 10-Tooth, 1-1/2" Bore, 2-1/4" LTB, 3/8" KY
WEST-307	3	VM010120	Woodruff Key, 3/8" x 1-1/4", Type E, #1210
WEST-302	3	-	Set Screw, Square Head, 3/8"-16 UNC x 3/4" Lg

WESTMILL PART NO.	QTY	CROSS REF.	DESCRIPTION
WEST-304	2	VM011288	Roll Tube, 3-3/4" OD x 0.125 Wall x 15' 0" Lg
G201	1	PB025116AB	Gudgeon, 1-1/4" x 2-1/8" Lg, Pin Hole
G202	2	-	Gudgeon, 1-1/4" x 5" Lg, 1/8" Cross hole
G213	1	-	Gudgeon, 1-1/4" x 5" Lg, 1/4" Woodruff KY
B363	2	RD-162	Roll Housing, Bottom
B371	2	RD-161	Roll Guide, Top
BU24	2	-	Bearing, Graphite, Infeed, 1-1/4" ID x 2-1/2" OD x 1-3/4" Lg
S201	2	-	Star Gear, 10-Tooth, 1-1/4" Bore, 2-1/4" LTB
SP211	1	RD-77	Sprocket, 8-Tooth, 1-1/4" Bore x 2-1/4" LTB, 1/4" KY
WEST-306	1	-	Woodruff Key, 1/4" x 1", Type #15
WEST-302	3	-	Set Screw, Square Head, 3/8"-16 UNC x 3/4" Lg

## MOORE LONGITUDINAL 12" VERTICAL DECK SPACING

SET AS SEEN BELOW: R01-0102-01P

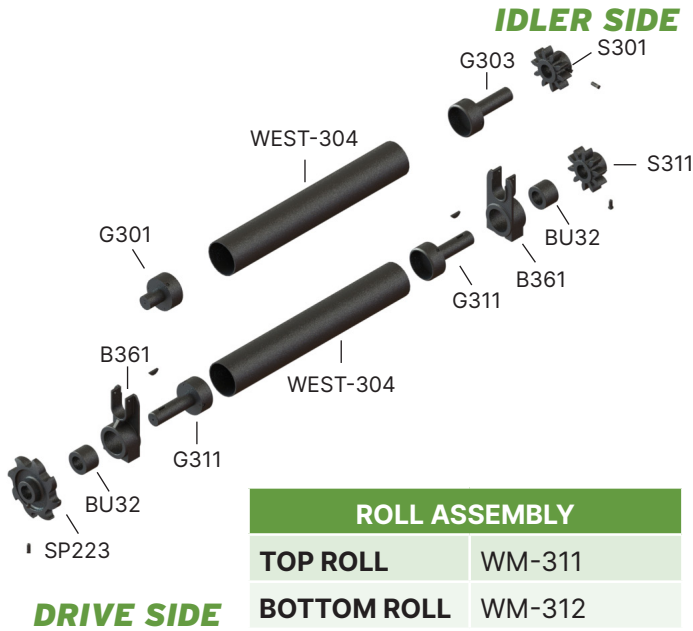

ROLL ASSEMBLY	
TOP ROLL	WM-311
BOTTOM ROLL	WM-312

## MOORE & PRENTICE LONGITUDINAL

15" VERTICAL DECK SPACING  
SET AS SEEN BELOW: R01-0101-01P

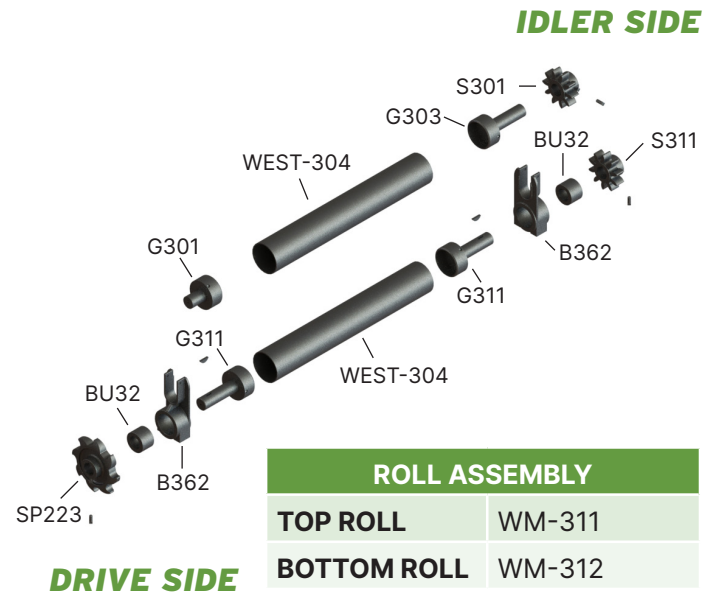

ROLL ASSEMBLY	
TOP ROLL	WM-311
BOTTOM ROLL	WM-312

WESTMILL PART NO.	QTY	CROSS REF.	DESCRIPTION
WEST-304	2	VM011288	Roll Tube, 3-3/4" OD x 0.125 Wall x 15' 0" Lg
G301	1	-	Gudgeon, 1-1/2" x 2" Lg
G303	1	-	Gudgeon, 1-1/2" x 5" Lg
G311	2	-	Gudgeon, 1-1/2" x 5" Lg, 1/4" Woodruff KY
B361	2	RD-165	Bearing Housing, 2-1/2" Bore
BU32	2	PC-066095	Bearing, Graphite, 1-1/2" ID x 2-1/2" OD x 1-3/4" Lg
S301	1	-	Star Gear, 10-Tooth, 1-1/2" Bore, 2-1/4" LTB
S311	1	-	Star Gear, 10-Tooth, 1-1/2" Bore, 2-1/4" LTB, 1/4" KY
SP223	1	RD-77	Sprocket, 8-Tooth, 1-1/2" Bore x 2-1/4" LTB, 1/4" KY
WEST-306	2	-	Woodruff Key, 1/4" x 1", Type #15
WEST-302	3	-	Set Screw, Square Head, 3/8"-16 UNC x 3/4" Lg

WESTMILL PART NO.	QTY	CROSS REF.	DESCRIPTION
WEST-304	2	VM011288	Roll Tube, 3-3/4" OD x 0.125 Wall x 15' 0" Lg
G301	1	-	Gudgeon, 1-1/2" x 2" Lg
G303	1	-	Gudgeon, 1-1/2" x 5" Lg
G311	2	-	Gudgeon, 1-1/2" x 5" Lg, 1/4" Woodruff KY
B362	2	RD-65	Bearing Housing
BU32	2	PC-066095	Bushing, Graphite, 1-1/2" ID x 2-1/2" OD x 1-3/4" Lg
S301	1	-	Star Gear, 10-Tooth, 1-1/2" Bore, 2-1/4" LTB
S311	1	-	Star Gear, 10-Tooth, 1-1/2" Bore, 2-1/4" LTB, 1/4" KY
SP223	1	RD-77	Sprocket, 8-Tooth, 1-1/2" Bore x 2-1/4" LTB, 1/4" KY
WEST-306	2T	-	Woodruff Key, 1/4" x 1", Type #15
WEST-302	3	-	Set Screw, Square Head, 3/8"-16 UNC x 3/4" Lg

CONVEYER COMPONENTS

ROLL TUBES & ASSEMBLIES

MAJOR COMPONENTS

DRYER DOORS

GENERAL COMPONENTS

WESTMILL EQUIPMENT

# ROLL SET

CONVEYOR COMPONENTS

ROLL TUBES & ASSEMBLIES

MAJOR COMPONENTS

DRYER DOORS

GENERAL COMPONENTS

WESTMILL EQUIPMENT

## PRENTICE LONGITUDINAL 12" VERTICAL DECK SPACING

(CHAIN HOLD DOWN BOLTED TO BEARING HOUSING)  
SET AS SEEN BELOW: R01-0107-01P

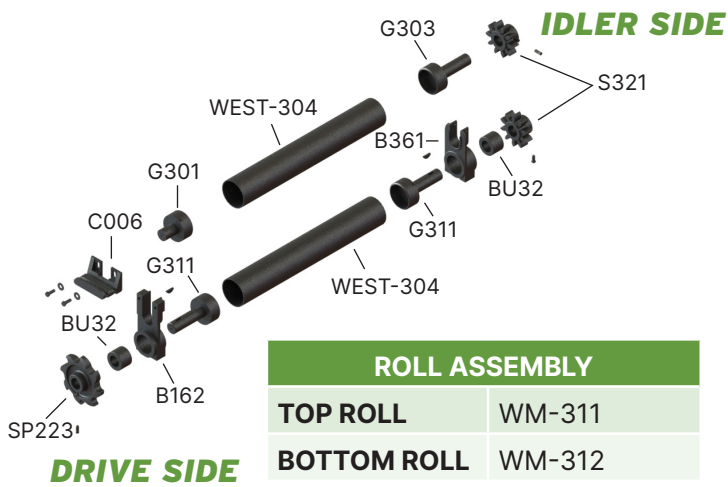

ROLL ASSEMBLY	
TOP ROLL	WM-311
BOTTOM ROLL	WM-312

WESTMILL PART NO.	QTY	CROSS REF.	DESCRIPTION
WEST-304	2	VM011288	Roll Tube, 3-3/4" OD x 0.125 Wall x 15' 0" Lg
G301	1	-	Gudgeon, 1-1/2" x 2" Lg
G303	1	-	Gudgeon, 1-1/2" x 5" Lg
G311	2	-	Gudgeon, 1-1/2" x 5" Lg, 1/4" Woodruff KY
B361	1	RD-165	Bearing Housing, 2-1/2" Bore
B162	1	C-30	Bearing Housing
BU32	2	PC-066095	Bushing, Graphite, 1-1/2" ID x 2-1/2" OD x 1-3/4" Lg
S301	1	-	Star Gear, 10-Tooth, 1-1/2" Bore, 2-1/4" LTB
S311	1	-	Star Gear, 10-Tooth, 1-1/2" Bore, 2-1/4" LTB, 1/4" KY
SP223	1	RD-77	Sprocket, Split, 8-Tooth, 1-1/4" Bore
C006	1	C30	Chain Hold Down, C30
WEST-306	2	-	Woodruff Key, 1/4" x 1", Type #15
WEST-302	3	-	Set Screw, Square Head, 3/8"-16 UNC x 3/4" Lg
WEST-322	2	-	Capscrew, Hex Head, 3/8"-16 UNC x 1" Lg
WEST-224	2	-	Washer, Narrow, 3/8" Dia. SAE

## PRENTICE LONGITUDINAL 15" VERTICAL DECK SPACING

(CHAIN HOLD DOWN BOLTED TO BEARING HOUSING)  
SET AS SEEN BELOW: R01-0106-01P

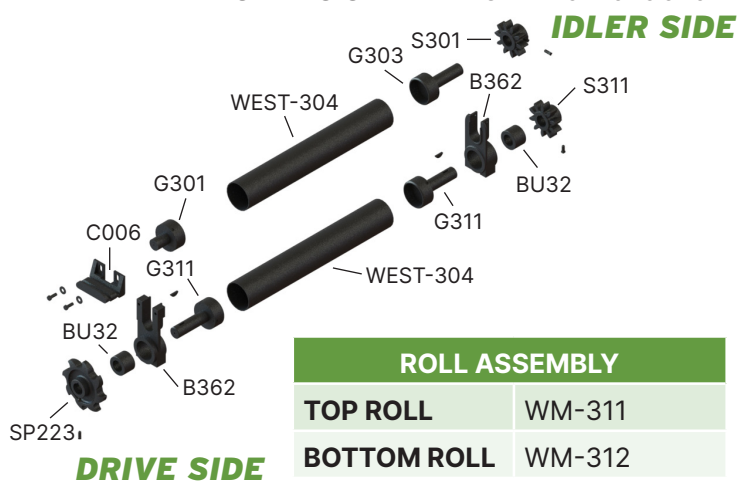

ROLL ASSEMBLY	
TOP ROLL	WM-311
BOTTOM ROLL	WM-312

WESTMILL PART NO.	QTY	CROSS REF.	DESCRIPTION
WEST-304	2	VM011288	Roll Tube, 3-3/4" OD x 0.125 Wall x 15' 0" Lg
G301	1	-	Gudgeon, 1-1/2" x 2" Lg
G303	1	-	Gudgeon, 1-1/2" x 5" Lg
G311	2	-	Gudgeon, 1-1/2" x 5" Lg, 1/4" Woodruff KY
B362	1	RD-65	Bearing Housing
B162	1	C-30	Bearing Housing
BU32	2	PC-066095	Bushing, Graphite, 1-1/2" ID x 2-1/2" OD x 1-3/4" Lg
S301	1	-	Star Gear, 10-Tooth, 1-1/2" Bore, 2-1/4" LTB
S311	1	-	Star Gear, 10-Tooth, 1-1/2" Bore, 2-1/4" LTB, 1/4" KY
SP223	1	RD-77	Sprocket, 8-Tooth, 1-1/2" Bore x 2-1/4" LTB, 1/4" KY
C006	1	C30	Chain Hold Down, C30
WEST-306	2	-	Woodruff Key, 1/4" x 1", Type #15
WEST-302	3	-	Set Screw, Square Head, 3/8"-16 UNC x 3/4" Lg
WEST-322	2	-	Capscrew, Hex Head, 3/8"-16 UNC x 1" Lg
WEST-224	2	-	Washer, Narrow, 3/8" Dia. SAE

# DRYER INSPECTIONS OPTIMIZE YOUR DRYER

Providing professional & objective insight into your veneer dryer.

Westmill performs on-site dryer inspections. These inspections help identify opportunities for production increases and energy savings that will provide an immediate payback on your investment.

#### Westmill Inspection Benefits:

- Maximize Production
- Reduce Emissions
- Reduce Energy Usage
- Increase Uptime
- Improve Veneer Quality



**LEARN MORE!**



# JET TUBES

CONVEYOR COMPONENTS

ROLL TUBES & ASSEMBLIES

MAJOR COMPONENTS

DRYER DOORS

GENERAL COMPONENTS

WESTMILL EQUIPMENT

Westmill supplies replacement jet tubes for any style of veneer dryer: COE, Moore, Raute Wood, Durand-Raute, Babcock, Moore-Jacksonville, Moore-Canada, Omeco, Fezer, Proctor Schwartz, and more.

Our jet tubes are interchangeable with OEM jet tubes. We maintain high quality standards at an excellent price.

### Custom Designs

At Westmill, jet tubes are more than just an 'off the shelf' item. Contact us to discuss what the best tube size, hole type, hole pattern and tube end is for your dryer. We have an endless range of custom capabilities.

Our standard jet tube is made from #16 gauge mild steel, but other thicknesses are available upon request.

We can offer beveled leading and trailing edges to eliminate the need to stock left-hand and right-hand jet tubes. We also offer beveled leading edge only, to help reduce the possibility of plug-ups in your dryer.

## JET TUBE LOCKING WEDGE

### & Eye Bolt Wedge Pin

Please contact our sales team for more information.



Jet Tube Locking Wedge WM-016



Eye Bolt Wedge Pin WM-226

## STANDARD & CUSTOM JET TUBE ENDS

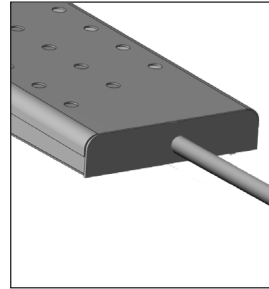

1/2" CR Round

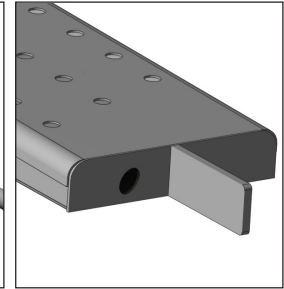

Flat Bar

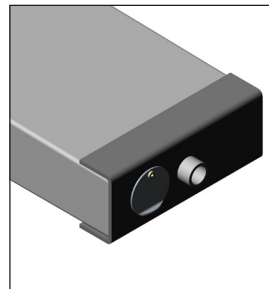

Eye Patch for air hose clean-out

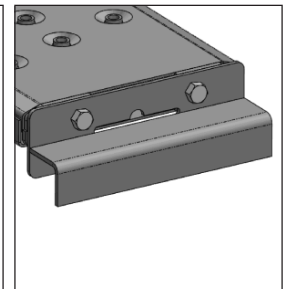

Raute (Reversible) Tube End

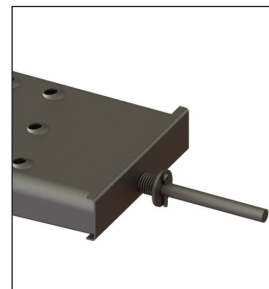

Spring-held clean-out Tube End

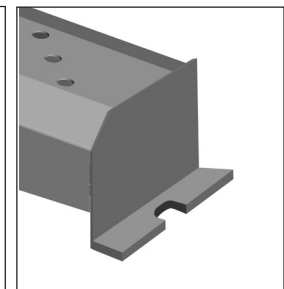

Extended Flange

## HOLE TYPES



Flat Slot



Hi-Efficiency Hole



Fingernail Hole

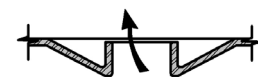

Raute Wood



## JET TUBES

WESTMILL PART NO.	DESCRIPTION	OEM
J01-0068	Jet Tube, M72, Top	Westmill, COE/USNR
J01-0069	Jet Tube, M72, Standard/Bottom	Westmill, COE/USNR
J01-0108	Jet Tube, M72, Top, Spring Clean Out	Westmill, COE/USNR
J01-0109	Jet Tube, M72, Bottom, Spring Clean Out	Westmill, COE/USNR
J01-0055-01	Jet Tube, WM, Standard, 1/2" Flat Mount Tab, Clean Out Hole, Hi-Eff Holes	Westmill
J01-0056-01	Jet Tube, WM, Top, 1/2" Flat Mount Tab, Clean Out Hole, Hi-Eff Holes	Westmill
J01-0055-05	Jet Tube, WM, Standard, 1/2" Flat Mount Tab, 2x Clean Out Holes, Hi-Eff Holes	Westmill
J01-0056-05	Jet Tube, WM, Top, 1/2" Flat Mount Tab, 2x Clean Out Holes, Hi-Eff Holes	Westmill
J01-0102	Jet Tube, M62, Bottom, Right, Non-Converted Hanger End, Extended Flange	COE
J01-0103	Jet Tube, M62, Top, Right, Non-Converted Hanger End, Extended Flange	COE
J01-0104	Jet Tube, M62, Bottom, Stepped End, Rod Nozzle, Hi-Eff Holes	COE
J01-0105	Jet Tube, M62, Top, Stepped End, Rod Nozzle, Hi-Eff Holes	COE
J01-0127	RAU-017 - Jet Tube, Reversible, Short Style, 190-3/8" Lg, Clean Out Hole	Raute
J01-0128	RAU-016 - Jet Tube, Reversible, Long Style, 192" Lg, Clean Out Hole	Raute
J01-0038-LH	Jet Tube, Cooling Section, Spring Clean Out, LH	Moore
J01-0038-RH	Jet Tube, Cooling Section, Spring Clean Out, RH	Moore
J01-0092-01	MOR-001 - Jet Tube, Non-Reversible, Type 1 (Pre 1970's)	Moore
J01-0092-02	MOR-002 - Jet Tube, Non-Reversible, Type 2 (Pre 1970's)	Moore
J01-0037	Jet Tube, 176-1/2" OAL	Cremona

## JET TUBE ACCESSORIES

WESTMILL PART NO.	DESCRIPTION	WESTMILL PART NO.	DESCRIPTION
J01-3385-01	Shaft Assembly, M72, Spring Clean Out, Jet Tube	J01-0079-02	WM-227 - Eye Bolt, Wedge Pin, Jet Tube Cover, 3-3/16" OAL
J01-0100	Formed Channel, M72, Spring Clean Out, Jet Tube	J01-0088	WM-450 - Standard Cover, M72, Jet Tube Air Distribution Plate
J01-0101	Shaft Attachment, M72, Spring Clean Out, Jet Tube (No Spring)	J01-3644-01	End Plate, Removable, Cremona, Jet Tube
905-571711	WEST-120 - Spring, Compression, Standard, for Jet Tube Cleanout	D02-1034	Locking Wedge, WM, Jet Tube, for 6-Deck Jet Dryer
905-571094	Compression Spring For Jet Tube - Std. Less 50% Compression	J01-0113	Locking Wedge, WM, Jet Tube
J01-0129	Mounting Bracket, Reversible Jet Tube, Raute	J01-0062	WM-016 - Jet Tube Locking Wedge, 6" x 1/4" x 7/8" (3/8" Nose)
J01-0079-01	WM-226 - Eye Bolt, Wedge Pin, Jet Tube Cover, 2-11/16" OAL	J01-0064	WM-016C - Jet Tube Locking Wedge, Custom, 6" x 1/4" x 7/8" (1/4" Nose)

CONVEYOR COMPONENTS

ROLL TUBES & ASSEMBLIES

MAJOR COMPONENTS

DRYER DOORS

GENERAL COMPONENTS

WESTMILL EQUIPMENT

# M-72 PLUG FANS

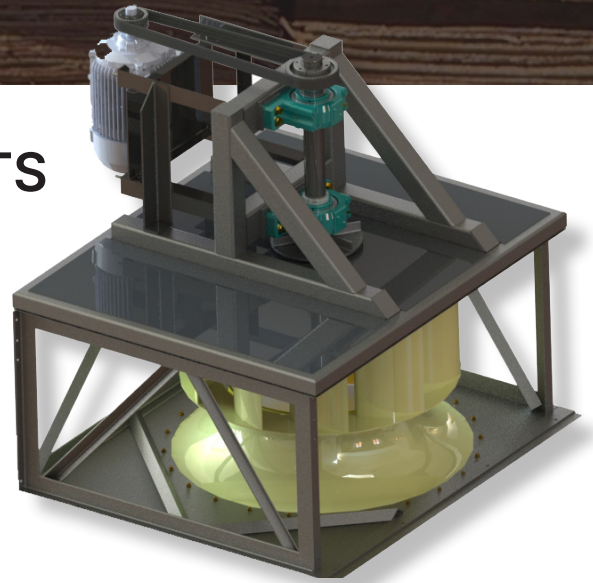

## M-72 REPLACEMENT FAN PARTS

	WESTMILL PART NO.	PART DESCRIPTION
	Fan-305	44" NYB Fan Class II 2-11/16" Bore
	Fan-405*	44" NYB Fan Class III 3-7/16" Bore*
	Fan-703	44" NYB Fan Inlet Cone
	CED-007 & CED-008	Dodge Fixed and Floating Bearings 2-11/16" Bore
	CED-014 & CED-015*	Dodge Fixed and Floating Bearings 3-7/16" Bore*
	WM-247	OEM M-72 Fan Shaft Seal
	WM-248	Cooling Wheel / Heat Slingers 2-11/16" Bore
	WM-257*	Cooling Wheel / Heat Slingers 3-7/16" Bore*
	WM-249	Fan Shaft Collars 2-11/16" Bore
	WM-449*	Fan Shaft Collars 3-7/16" Bore*

**WESTMILL™ HEAVY DUTY FAN UPGRADE** Learn more about our replacement Hot-Air Circulation fans. **PAGE 64**

- PLUG FAN UPGRADE OPTIONS\***
- Heavy duty Class III fan for increased air flow capability - includes 3-7/16" shaft bearing
  - Spring Packing Gland Seal System
  - Guard systems
  - Lubricant systems
  - Fan inlet screens
  - Inboard or Overhung motor mounts

**MORE REPLACEMENT PARTS**  
Ask our sales team for details regarding:

- Shafts
- Motors

\* Westmill Upgrade options | Please contact our sales team for custom sizes.

## WESTMILL EXCLUSIVE HIGH-TEMPERATURE DODGE™ BEARINGS

Westmill uses custom designed, proprietary HI-TEMP DODGE™ Fan Shaft bearings on the dryer circulation fans. Dodge and Westmill worked together to develop these dryer fan-shaft bearings specifically for this application! Only available from Westmill.



CONVEYOR COMPONENTS

ROLL TUBES & ASSEMBLIES

MAJOR COMPONENTS

DRYER DOORS

GENERAL COMPONENTS

WESTMILL EQUIPMENT

## SPRING PACKING GLAND SEAL SYSTEM

To prevent dryer emissions from escaping via the circulation fan shafts, Westmill has developed an innovative Self Adjusting, Spring Tensioned Fan Shaft Seal System.

Without a proper fan shaft seal, excess heat and contamination from leaky fan-shaft packing glands cause the lower fan shaft bearings to fail at approx. 10:1 ratio vs the upper fan shaft bearing failures.

Westmill's new Spring Loaded Fan Shaft Seal System can permanently solve this.

Proven in over 250 fan installations, this shaft seal system utilizes a heavy SS Spring to apply constant pressure against high temperature graphite packing material to create a highly effective and long lasting fan shaft seal *that simply does not leak!*

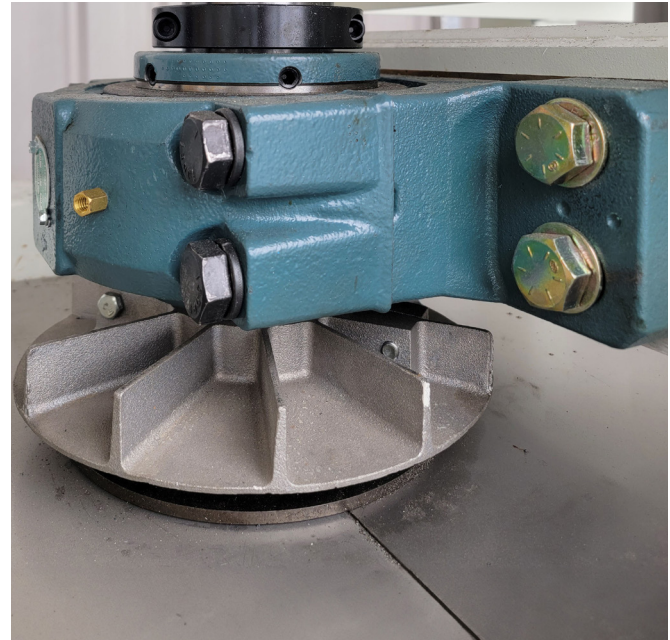

CONVEYOR COMPONENTS

ROLL TUBES & ASSEMBLIES

MAJOR COMPONENTS

DRYER DOORS

GENERAL COMPONENTS

WESTMILL EQUIPMENT

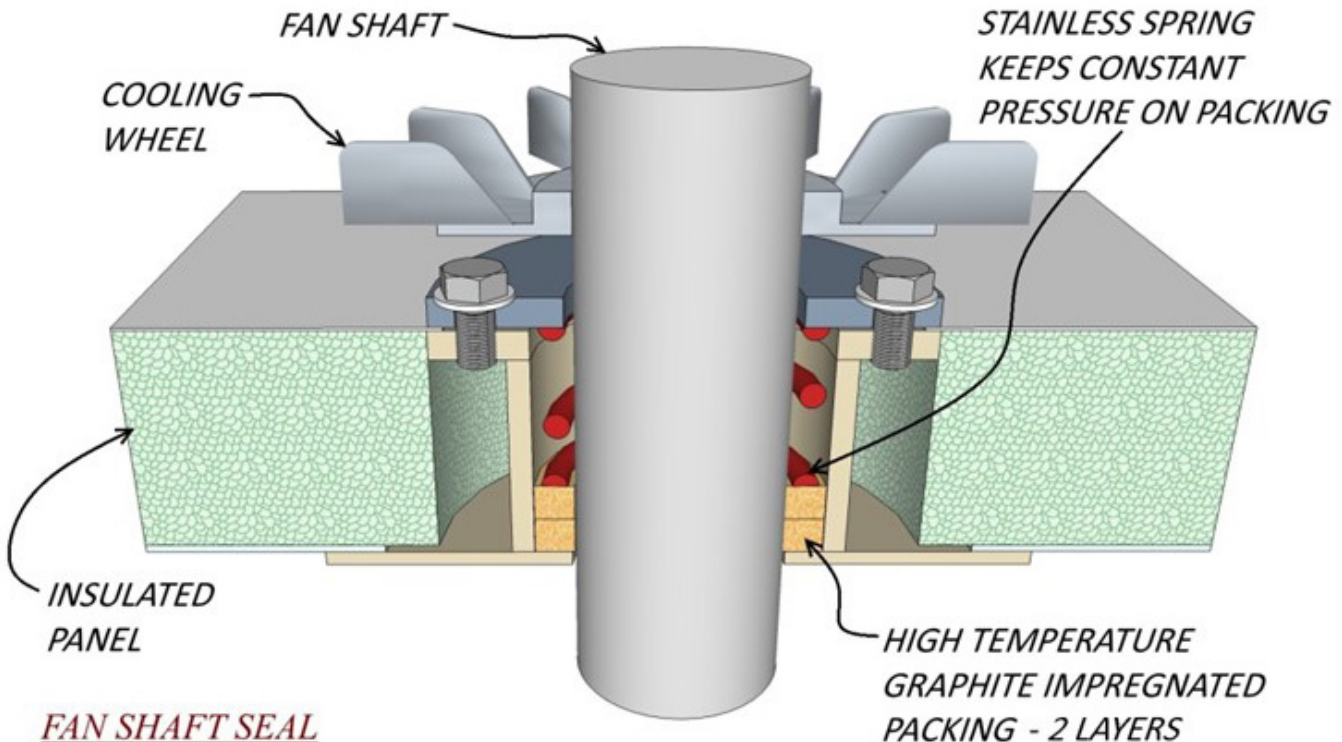

# FAN HARDWARE

## NEW YORK BLOWER FANS

New York Blower has been Westmill's long-time and trusted supplier of Hot Air Circulation Fan Wheels, Cooler Vaneaxial Fans and Backward Inclined Fans. As a New York Blower OEM, Westmill offers quick deliveries and great pricing for New York Blower fans and components

### Plug Fan – Hot Air Circulation Fans on Jet Dryers

Plug fans are used in applications where the system plenum acts as the fan housing. The fan combines versatility with compact design to reduce overall system costs. This is achieved while maintaining operating efficiencies nearly equal to conventional housed fan equipment. NYB's high-efficiency AcoustaFoil airfoil blade will provide the highest volume airflow at the lowest required horsepower.

### Inlet Cone

Aerodynamically designed, spun inlet cones are matched for optimum efficiency with wheel and housing components.

### Shaft Cooler

Also known as a heat slinger, a shaft cooler dissipates heat emitted from a hot airstream to protect a fan shaft, bearings, drive components, etc.

### Vaneaxial Fans

Axial fans are used in process applications where space is at a premium. Air flows through fans parallel to the shaft moving outward in the same direction it flowed inward (axially). These inline fans are used for creating a high volume of airflow in lower pressure applications. For example: on a Veneer Dryer Cooler Intake and Exhaust Duct Fans.

### Backward Inclined Fans

NYB centrifugal fans are sturdy, reliable, and capable of operating to various conditions. In dryer applications they are used for hot-air circulation (on longitudinal dryers), for exhaust air flow and combustion air flow for gas burners.

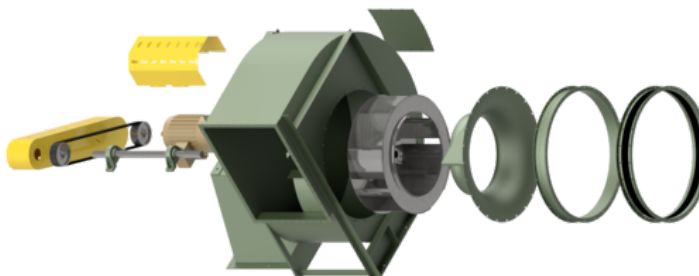
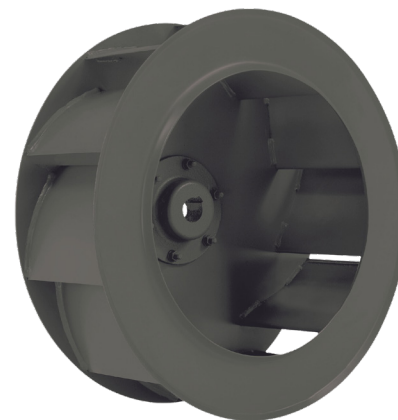

CONVEYOR  
COMPONENTS

ROLL TUBES &  
ASSEMBLIES

MAJOR  
COMPONENTS

DRYER DOORS

GENERAL  
COMPONENTS

WESTMILL  
EQUIPMENT

## MAXON CROSSFIRE® LINE BURNER

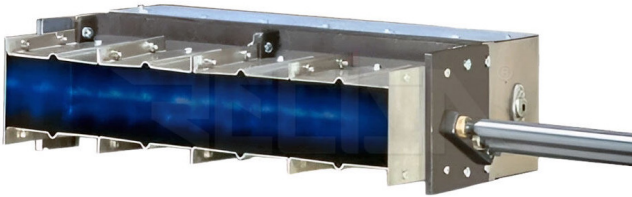

Westmill was the first company ever to install & use a MAXON APX style Burner in a veneer dryer application, and with great success. This was installed in 2005 at West Fraser – Edmonton's plant.

Maxon's APX Line Burners are the cost-effective solution for Standard NOx emissions – to replace burners on existing dryers. In low NOx dryer applications, we use Maxon's CROSSFIRE Line burner to meet the new stringent Low NOx emission requirements. We can also supply all replacement parts for your existing Maxon or Eclipse gas burners.

### MAXON CROSSFIRE LINE BURNER

Maxon CROSSFIRE® Burners are nozzle-mixing, modular line burners designed for a variety of fresh and re-circulated industrial air process heating applications. The low NOx burner is available in straight, grid, and insert cartridge sections which are used to spread heat across your duct for very uniform temperature distributions.

The CROSSFIRE® Burner can be designed within a system to allow for up to 2,500,000 BTU/hr/ft (730 kW/ft) while producing extremely low emissions of both NOx and CO. You can combine CROSSFIRE® Low NOx Burners with SMARTFIRE® Intelligent Combustion Controls for optimal control of emissions and efficiency.

One of the most important elements of Maxon's Low NOx burner, is the MAXON SMARTLINK® MICRO-RATIO® VALVE (MRV).

The Maxon SMARTLINK® MRV is an industrial parallel positioning system for combustion applications providing a high degree of precision, repeatability, tamper resistance, and durability. In addition, SMARTLINK® MRV interfaces with all burner management and flame safety systems, simplifying retrofit applications. The system is simple to set up and does not require a personal computer in the field for commissioning.



# Honeywell



CONVEYOR  
COMPONENTS

ROLL TUBES &  
ASSEMBLIES

MAJOR  
COMPONENTS

DRYER DOORS

GENERAL  
COMPONENTS

WESTMILL  
EQUIPMENT

# STEAM COILS

## ARMSTRONG HUNT STEAM COILS



To heat our dryers Westmill provides high-efficiency Single Pass steam coils manufactured specially for Westmill by Armstrong Hunt. AH are arguably the #1 coil manufacturer in the world and have provided Westmill's Veneer Dryer coils for decades.

These steam coils are designed specifically by Armstrong Hunt for veneer dryer applications with proprietary fin spacing and the tube spacing geometry proven to provide better plug-up resistance and allowing debris to pass through the coil bank.

With a 0.134" tube-wall thickness, an embedded 0.030" thick fin and with an 'anti-debris plug-up' design, we guarantee these coils will provide ***the best overall steam coil performance in a veneer drying application available today!***

Westmill stands 100% behind Armstrong Hunt's steam coils and products. And if Westmill is going to stand firmly behind them, failure is not an option!

Let Westmill supply all your dryer heating needs.

# SAVE TIME AND MONEY

Please contact our sales team for more information regarding custom steam coils, steam traps, and replacement parts.



Inverted Bucket Armstrong Steam Trap - 300 Series



Float & Thermostatic Armstrong Steam Trap



# UPGRADE YOUR DRYER TECHNOLOGY

**Is outdated technology effecting overall production?**

With a Westmill Dryer Technology Upgrade, bring your dryer back to "better-than-new" condition. All components necessary to upgrade your system are engineered and supplied by Westmill exclusively. By re-using components such as the conveyor, framework, and other parts, provide a significant savings versus a new build.

**Benefits of a Technology Update:**

- Increased Dryer Production
- Reduced Energy Usage
- Improved Veneer Quality
- Reduced Downtime
- Reduced In-plant Emissions
- Reduced Incidences of Dryer Fires
- Reduced Plug-ups



**LEARN MORE TODAY!** [www.westmill.com](http://www.westmill.com)



# QUICK-CHANGE SYSTEM 1-2-3™



Westmill's **Quick-Change System 1-2-3™** Dryer Door Seal System is a cost effective solution to seal your dryer. **System 1-2-3™** incorporates a stainless steel "D" profile seal that quickly and easily attaches to a permanent backing plate that is affixed to your dryer door frames.

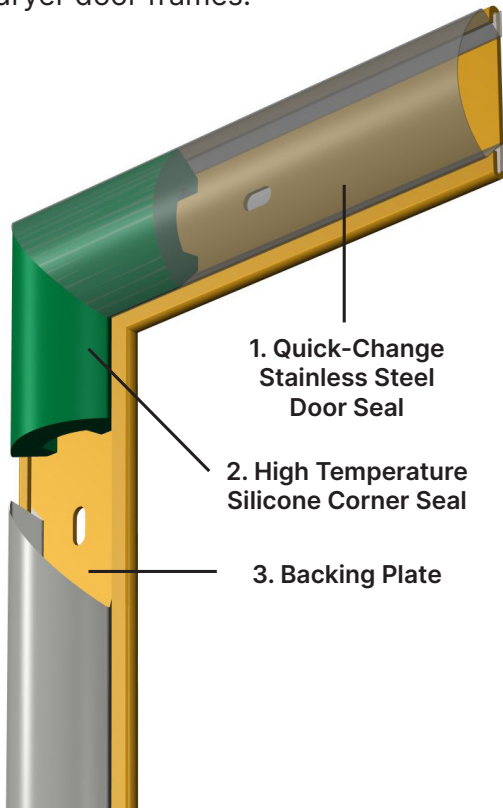

- 1. Quick-Change Stainless Steel Door Seal
- 2. High Temperature Silicone Corner Seal
- 3. Backing Plate

## SYSTEM 1-2-3™: A SUPERIOR & COST EFFECTIVE SOLUTION

### COST:

**First-time installation:** Same cost as tadpole seals  
**Future replacement:** Half the cost of tadpole seals

### INSTALLATION TIME:

**Tadpole seal installation:** Over 2 hours/Door  
**Quick-Change System 1-2-3 seal:** Only 5 minutes/Door

Unlike typical tadpole seals, the stainless **Quick-Change System 1-2-3™** seal can withstand direct exposure to nuisance fires.

High-Temperature silicone corner seals provide a leak-free corner joint and a perfect fit of the stainless seals.

WESTMILL PART NO.	NAME & LENGTH
<b>1. STAINLESS DOOR SEAL</b>	
WEST-335	72" Stainless Steel Door Seal
WEST-333	78" Stainless Steel Door Seal
WEST-332	96" Stainless Steel Door Seal
WEST-331	120" Stainless Steel Door Seal
WEST-327	144" Stainless Steel Door Seal
<b>2. CORNER SEAL</b>	
WEST-326	High-Temperature Silicone Corner Seal
<b>3. BACKING PLATE*</b>	
WEST-334	72" Mild Steel Backing Plate
WEST-330	96" Mild Steel Backing Plate
WEST-329	120" Mild Steel Backing Plate
WEST-328	144" Mild Steel Backing Plate

\*Backing plates also available in stainless steel.

## WESTMILL ARTICULATING DOOR HARDWARE PATENT NO. 6,447,807

Westmill's Patented Articulating Door Hardware is the most functional and easily adjustable door hardware available on the market, **with over 8,000 sets in operation today!**

Westmill's articulating hinges align the door to pull 'straight-away' from the door seal before swinging when opening. When closing, our articulating hardware provides a very positive door seal and closure (compared to standard OEM style hardware) while greatly increasing the door seal life.

We designed our door hardware to be compatible with the mounting hole patterns found on COE M-62 and M-72 veneer dryers. If your dryer's doors and seals are in good condition, simply adding Westmill's Door Hardware will provide your door positive closure preventing dryer leakage.

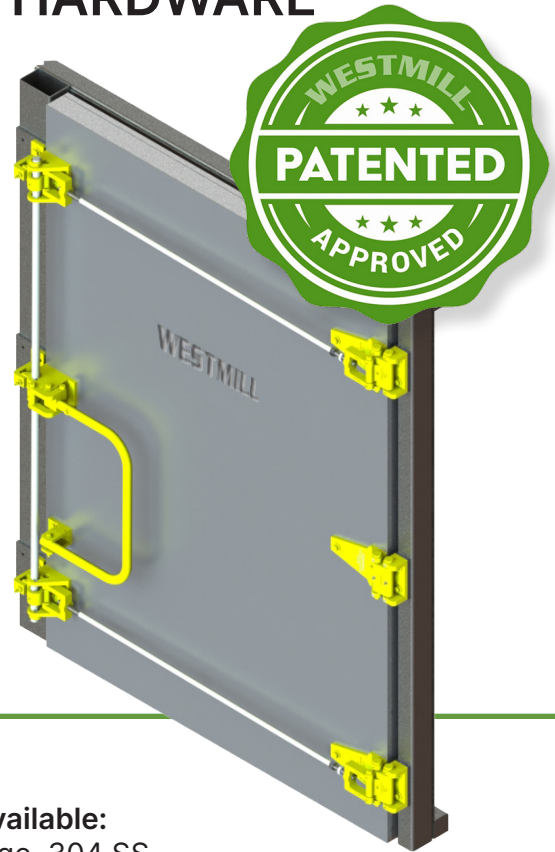

CONVEYOR COMPONENTS

ROLL TUBES & ASSEMBLIES

MAJOR COMPONENTS

DRYER DOORS

GENERAL COMPONENTS

WESTMILL EQUIPMENT

## DRYER DOORS

Westmill has been supplying dryer doors to the veneer industry for more than 45 years. Westmill doors are available in 'box' style and 'floating-skin' style. Our 'floating-skin' style doors are warp resistant and are easily installed onto your existing dryer. To reduce warping caused by thermal expansion, the skins 'float' independently of the door frame itself. The inside door skin has flat bar stiffeners that prevent 'oil canning'.

Westmill doors are available in all sizes for any dryer. Our doors can be designed to fit your existing OEM hardware and can be quickly changed out during a regular maintenance shift.

### Options Available:

- 16-gauge, 304 SS
- Painted mild-steel
- Hole patterns to fit any OEM dryer
- Westmill's patented articulating door hardware
- Welded nuts to allow you to use a lifting eye to mount the doors

### Standard Features:

- Strong structural steel interior framework
- Robust mountings for door hardware
- Easy installation

## SAVE TIME QUICK-INSTALL DOOR CARTRIDGE

Give yourself the edge. Replace leaky dryer doors that are draining your company's profitability with Quick-Install Door Cartridge Systems from Westmill.

Seal-weld the door cartridge to your existing door frame. The result - solid airtight frame!

This airtight installation will:

- Prevent heat loss
- Reduce emissions
- Improve your mill's efficiency
- Lower your overall operational costs

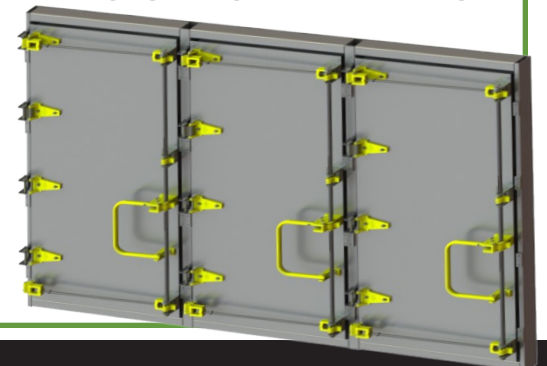

# DOOR HARDWARE

## WESTMILL ARTICULATING DOOR HARDWARE

CONVEYOR COMPONENTS

ROLL TUBES & ASSEMBLIES

MAJOR COMPONENTS

DRYER DOORS

GENERAL COMPONENTS

WESTMILL EQUIPMENT

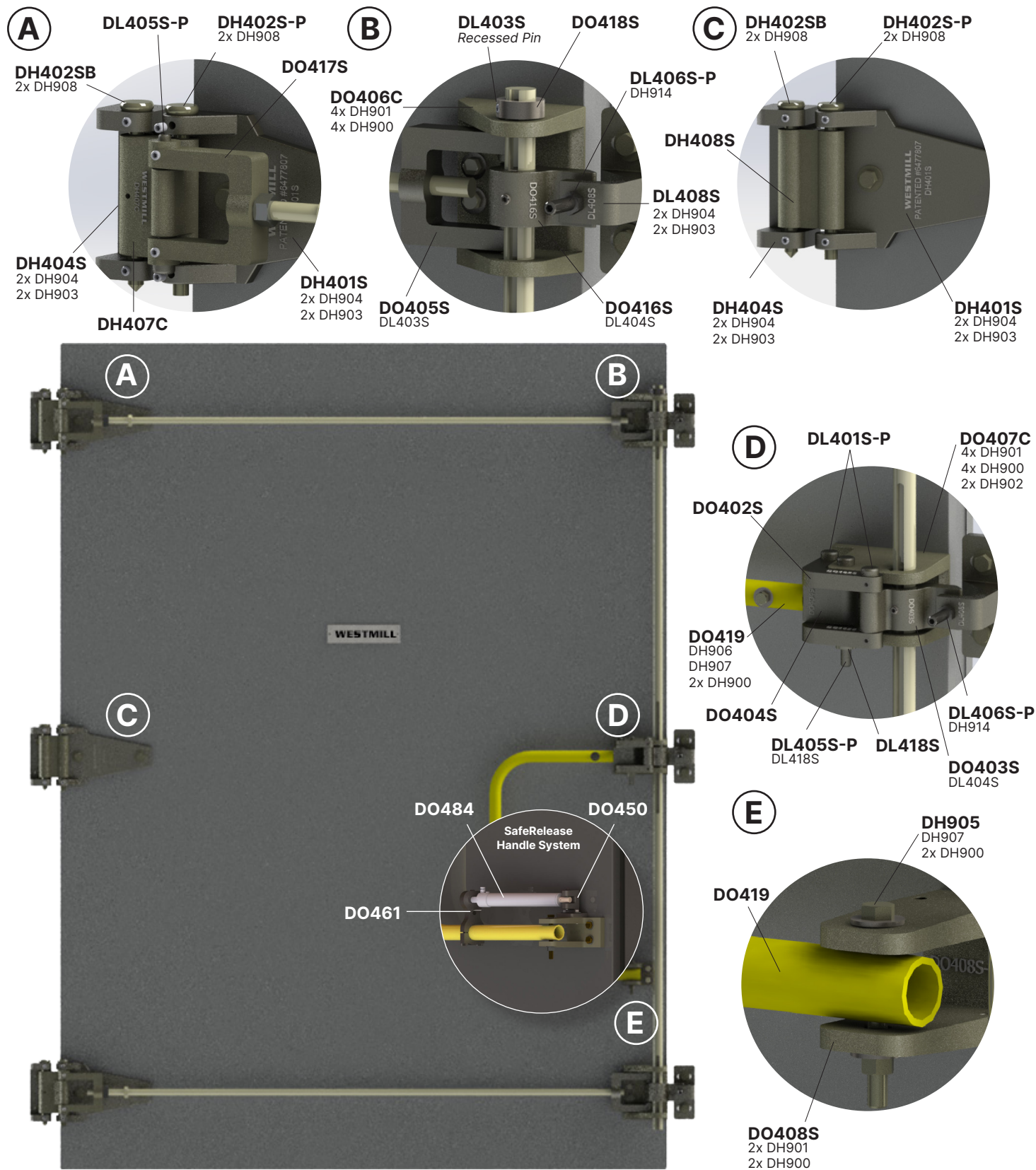

As shown above, right hand door

## WESTMILL DOOR HARDWARE

WESTMILL PART NO.	QTY.	PART NAME
DH401S	3	Hinge Door Plate
DH402S-P	3	Capped Pin, Flat-Bottom 5/8" X 7"
DH402SB	3	Capped Pin, Bullet Bottom 5/8" X 7"
DH404S	3	Post Mount, Single
DH407C	2	Cross Arm Hinge
DH408S	1	Center Hinge
DO448	2	Cross Arm Rod Assembly
DL401S-P	2	Capped Pin 1/2" x 3 1/2"
DL403S	2	Straight Pin 1/2" x 4"
DL405S-P	3	Capped Pin 1/2" x 5"
DL406S-P	3	Latch Adjustment Bolt
DL408S	3	Latch, Post Mount
DO402S	2	Eccentric Lock Connector
DO403S	1	Middle Lock Tab
DO404S	1	Upper Handle Link
DO405S	2	Cross Arm Clevis LH Thread
DO417S	2	Cross Arm Clevis RH Thread
DO406C	2	Cross Arm Latch Base
DO407C	1	Center Latch Base
DO408S	1	Bottom Handle Base <i>(SafeRelease™ Ready)</i>
DO415	1	Vertical Main Shaft
DO416S	2	Cross Arm Lock Tab
DO419	1	Door Handle

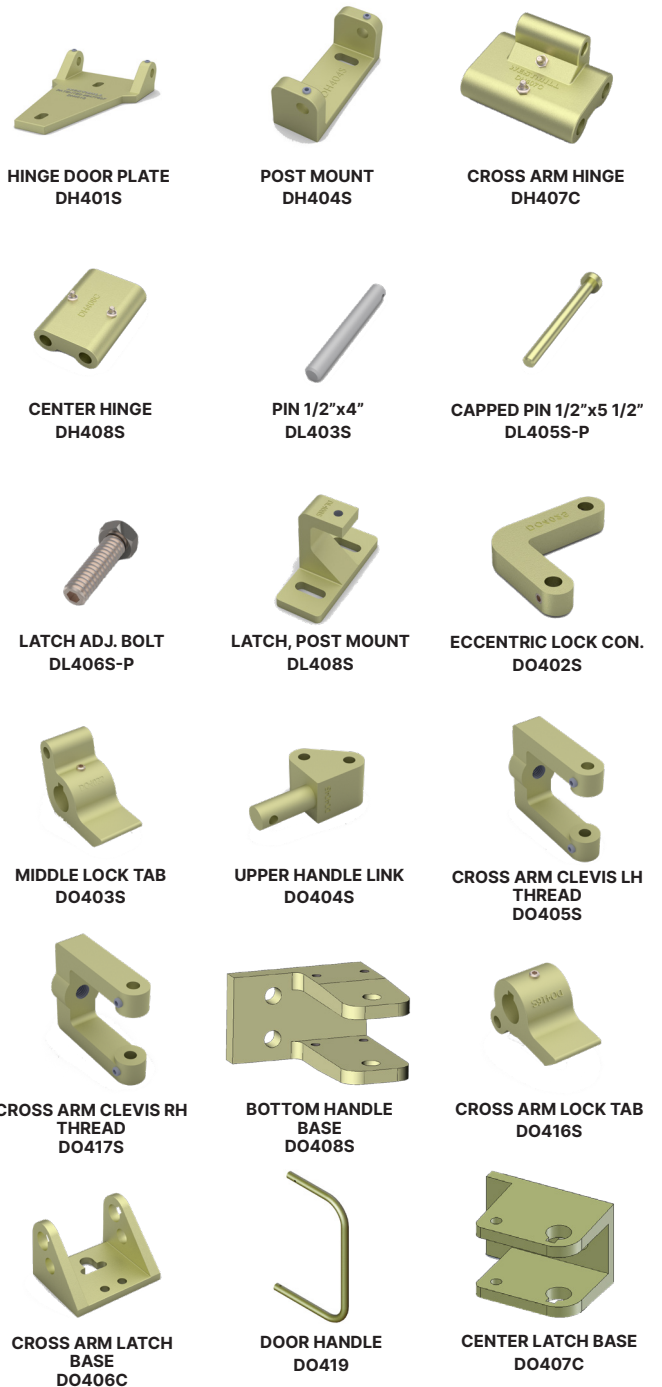

CONVEYOR COMPONENTS

ROLL TUBES & ASSEMBLIES

MAJOR COMPONENTS

DRYER DOORS

GENERAL COMPONENTS

WESTMILL EQUIPMENT

DOOR ASSEMBLY	
<b>DOOR HARDWARE FULL BASE KIT</b>	WM-DHW-1
<b>DOOR HANDLE LOAD-DAMPENER KIT</b>	WM-DHW-A
<b>FULL BASE &amp; DOOR HANDLE LOAD-DAMPENER KIT</b>	WM-DHW-D

# DOOR HARDWARE









## SafeRelease™ HANDLE SYSTEM PATENT NO. 12,071,786

A recent innovation by Westmill is the development of our SafeRelease™ Handle System load-dampener. When a conventional dryer door is opened, there is a tremendous amount of force on the handle due to the spring-compression of the door seal material. As soon as the door handle opens beyond the self closing position, the force of the compressed door seal quickly loads force onto the handle.

By contrast, when a dryer door equipped with Westmill's SafeRelease™ Handle System load-dampener is opened, the force of the door handle is completely controlled and simply does not create a human strike hazard.



	WESTMILL PART NO.	QTY.	PART DESCRIPTION
	DH950	2	Washer, Lock, 1/4" Dia, 1/16" thick, 1/2" OD, Mechanical Zinc Finish
	DH931	2	Cap Screw, Socket Head, 1/4"-20 UNC x 1" Lg, Gr5
	DL486	2	Pin, Clevis, 1/4" x 1-9/16" Usable Length
	DL490	2	Pin, Cotter, Cylinder, 1/16" x 1" Lg
	DO484	1	Rate Control Cylinder, Non-Adjustable Setting 6, 01 Fluid, SP26140
	DO408S	1	Bottom Handle Base, Door Hardware
	DO461	1	Cylinder Clamp, 1" ID Mount, w/Hardware, for Rate Controller
	DO450	1	Clevis, Mounting, for Door Rate Control Cylinder, Cast

CONVEYOR COMPONENTS

ROLL TUBES & ASSEMBLIES

MAJOR COMPONENTS

DRYER DOORS

GENERAL COMPONENTS

WESTMILL EQUIPMENT

# OTHER OEM DOOR PARTS

## COE DOOR

## MOORE DOOR

## PRENTICE DOOR

	PART NO.	CROSS REF. NO.	NAME		PART NO.	CROSS REF. NO.	NAME		PART NO.	CROSS REF. NO.	NAME
	DH101	CP009916 PC090679	Single Hinge Butt		DH201	Moore RD-32	Double Hinge Butt		DH301	Prentice C-16	Double Hinge Butt
	DH102	CP007914A PC0312820A	Hinge Strap		DH202	Moore RD-36	Single Hinge Butt		DH302	Prentice C-15	Single Hinge Butt
Custom	DH205	Moore RD-14B PC-080539	Hinge Block		DH203	Moore F-570	Hinge Strap		DH303	Prentice C-13	Hinge Strap
	DL101	CP009812 PC030058	Cam Roller Block		DH204	RD-33	Hinge Butt		DL301	Prentice C-11	Latch Shoe
	DL102	-	Latch Roller Pin		DL201	Moore RD-34	Latch Block		DL302	Prentice C-12	Latch Cam, left
	DL103	-	Latch Roller		DL202	Moore RD-35	Latch Handle, left		DL303	Prentice C-12	Latch Cam, right
	DL104	COE 9810	Latch Shoulder Bolt		DL203	Moore RD-35	Latch Handle, right		DL304	Prentice C-17	Latch Handle Clip
	DL105	COE 9812	Latch Roller Block Assembly		DL204	Moore RD-31	Latch Butt Plate, double		DL305	-	Latch Block
	DL106	-	Shake-proof Washer		DL205	Moore RD-29	Latch Butt Plate, single		DL306	-	Latch Bearing
	DO101	CP009915 PB014962-B	Cam Handle, left		DL206	Moore RD-35	Latch Hook		DO301	-	Door Handle
	DO102	CP009914 PB014962-A	Cam Handle, right		DO201	-	Hinge Pin 5/8" diameter x 6 1/2" long		DO302	-	Hinge Pin 1/2" diameter x 6 1/4" long
	DO103	DL405S-P & DO103	Hinge Pin 1/2" diameter x 4" long		DO202	-	Hinge Pin 5/8" diameter x 5" long				

CONVEYOR  
COMPONENTS

ROLL TUBES &  
ASSEMBLIES

MAJOR  
COMPONENTS

DRYER DOORS

GENERAL  
COMPONENTS

WESTMILL  
EQUIPMENT

# DOOR SEAL & DRYER THERMOMETER

## TADPOLE-STYLE DOOR SEAL

Tadpole seals are recommended for old uneven doors and door frame surfaces.

- Stainless mesh core conforms to the irregular surfaces
- Suitable for all dryer temperatures and heat types
- Made from non-asbestos material
- Chemical resistant

Contact our sales team for more custom sizes & materials.

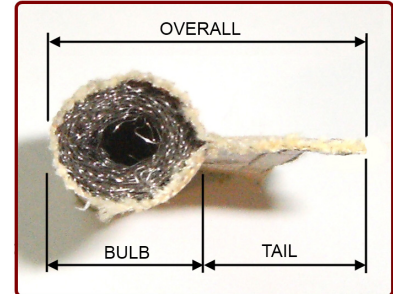

	WESTMILL PART NO.	BULB DIAMETER	TAIL	JACKET
	WEST-303B	3/4"	1"	Teflon Coated Fiberglass
	WEST-303B1	1"	1-1/4"	Teflon Coated Fiberglass
	WM-303K	3/4"	1-1/8"	Teflon-Coated Kevlar
	WEST-400	7/8"	5/8" x 2"	Teflon-Coated Kevlar
	WEST-732	7/8"	11/16" x 2"	Silicone-Coated E-Glass

## ADJUSTABLE VIEWING ANGLE LONG-REACH BIMETAL THERMOMETER

View real time temperatures of the dryer zones with our long-reach bimetal thermometer.

- Easy to install:
  - No wires and hook ups
  - Simply install a 1/2NPT hole, insert probe and tighten
- Stem length of 12" (other lengths available)
- Stainless steel construction
- Adjustable head for viewing from all angles
- Large easy-to-read digits on the 5" Face
- Calibration adjustment
- Accurate to +/- 1%



Part number GAGE51201

### SEAM TAPE & HIGH-TEMP ROPE

A wide variety of sizes and thicknesses PLUS an extensive selection of materials available.





# DISCOVER WESTMILL™ EXCLUSIVE TECHNOLOGY



**LEARN MORE TODAY!**

[www.westmill.com](http://www.westmill.com)



# PLUG-UP DETECTION & PARTS

CONVEYOR COMPONENTS

ROLL TUBES & ASSEMBLIES

MAJOR COMPONENTS

DRYER DOORS

GENERAL COMPONENTS

WESTMILL EQUIPMENT

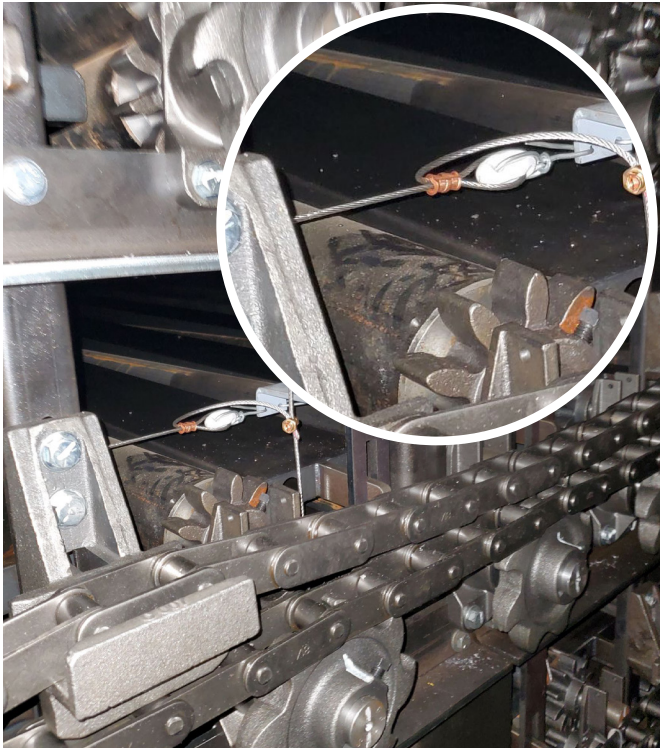

## DRYER PLUG-UP DETECTION

Two of the most common causes for dryer downtime are veneer plug-ups and dryer fires. Westmill's Plug-Up Detection System helps to reduce the frequency and severity of both.

Westmill offers a Dryer Plug-Up Detection System that can be installed on any type of dryer. We offer a ground-wire style of system common to the veneer drying industry.

### How it works:

When a plug-up occurs, the veneer lifts the top conveyor roll. When this roll contacts the trip-wire an electrical signal is sent to the control center and a visual signal is given to the dryer operator. The visual alarm can be sent to multiple stations: a control box with lights and/or an electronic HMI display screen (e.g. Allen-Bradley Panel View). The operator can then stop feeding the dryer, diagnose the problem and correct the situation.

### Benefits:

By identifying dryer plug-ups before they become major problems, you can:

- Maximize your dryer running time
- Help prevent fires from starting
- Prevent costly damage to dryer rolls, jet tubes and the main dryer frame

## WESTMILL™ PROGRAMMING AND CONTROLS

Learn more about our available programming and controls.

PAGE 69

# PLUG-UP DETECTION PARTS

	WESTMILL PART NO.	PART NAME
	PD-1015	Wire 7 × 7, Stainless Steel
	PD-1	Insulator Bracket
	PD-1004R	Red Lamp Lens
	PD-1005	Threaded Teflon Thru Panel Insulator
	PD-1006	Spring, Stainless Steel 7-5/8" Overall length
	PD-1025	Bolt - 3.5"
	PD-1026	Steel Nut
	PD-1045	Transformer
	PD-1067	Rectifier
	PD-1090	Split Bolt Wire Clamp
	PD-1162	Lamp Holder

	WESTMILL PART NO.	PART NAME
	PD-1007A	Wire Clip for Insulator
	PD-1008	Jam Nut for Threaded Insulator Rod, SS
	PD-1012	Galvanized Wire, 3/32"
	PD-1022	Stand Off Insulator
	PD-1024	Bolt - 2"
	PD-1327	Bulb
	PD-1716	Washer
	PD-9632	Porcelain Insulator with Wire
	PD-0002	Wire - 7 × 19
	PD-0059	Wire Crimp

CONVEYOR COMPONENTS

ROLL TUBES & ASSEMBLIES

MAJOR COMPONENTS

DRYER DOORS

GENERAL COMPONENTS

WESTMILL EQUIPMENT

Westmill can also supply all replacement parts for your existing Plug-Up Detection system, whether we supplied it initially or not.

# MOISTURE DETECTOR PARTS

	WEST. PART NO.	CROSS REF. NO.	PART NAME		WEST. PART NO.	CROSS REF. NO.	PART NAME	
CONVEYOR COMPONENTS		WEST-12	280-1513-00 MT-1090	Moisture Detector Brush All makes and models		CAR-004	261P04	1/4" NPT Nut w/ plastic ferrule
ROLL TUBES & ASSEMBLIES		SPE-001	675-0089-00	Inker Valve with pigtail		COE-059	PC-111	Power Supply Card
		SPE-004	B-736-S24	Inker Valve Solenoid Coil		COE-060	PC-121	Control Circuit Card
		MT-1071	-	Electrical Connector for Inker Valve		COE-061	PC-122	Ref. Amplifier Card
MAJOR COMPONENTS		MT-1078	B60-S002	Inker Valve Repair Kit (Plunger, Spring, O-Ring)		COE-062	PC-135	Auto Calibrate Detector Card
		MT-TOOL	-	Disassembly Tool for Inker Valve		WEST-194	598-0033-00	Detector Spring
DRYER DOORS		WM-091	Ward	Inker Valve Bracket		WM-165	625-0269-04	3-gal. Ink Pot w/t Fittings
		WM-038	599-0083-00	Ward Moisture Brush Guard	No Image	WM-206	675-0094-00	Moisture Brush Holder
		WARD-001	Ward 200C	Acrylic Insulator for Ward #220C		WM-001	CY-74	Ink Filter Housing
GENERAL COMPONENTS		WEST-05	268-P	Standard Tube Fitting 1/4" tube x 1/8" NPT		FIL-002	CY-75	Ink Filter Element
		CAR-002	261-P	Quick Connect 3/8" tube x 1/4" NPT w/ pilot check valve		ELL-003	CY-55	Poly Brush Holder
		CAR-003	261-P	Quick Connect 1/4" tube x 1/8" NPT w/ pilot check valve		ELL-004	CY-56	Aluminium Brush Holder
WESTMILL EQUIPMENT								

## MARKING INK FOR VENEER & LUMBER

Westmill supplies plywood, LVL and veneer mills with permanent or disappearing marking inks for use in dry-end brush-style veneer moisture detectors. Our inks are compatible with Ventek, Ward, Elliot Bay, COE, Raute Wood, Durand-Raute and other ink spraying moisture detectors. Our inks are specially formulated with cleaning surfactants to reduce clogging and freezing of spray valves, while continuously keeping the lines free of debris and contaminants.

### Permanent Marking Ink

Sold by the case of four 1-gallon (U.S) jugs. 5-gallon (U.S.) pails and 55-gallon (U.S.) drums available upon request.

WESTMILL PART NO.	COLOURS	WESTMILL PART NO.	COLOURS
ACI-007	Black	ACI-011	Green
ACI-008	Blue	ACI-012	Red
ACI-009	Yellow	ACI-013	Purple
ACI-010	Orange	ACI-017	Brown

### Disappearing Marking Ink

Westmill disappearing ink goes on full-strength but vanishes in just minutes. Perfect for high-quality veneers that you don't want to degrade simply due to ink spray.

#### 5-Gallon Pail

WESTMILL PART NO.	COLOURS
ACI-001	Red
ACI-004	Blue

#### 55-Gallon Drum

WESTMILL PART NO.	COLOURS
ACI-002	Red
ACI-003	Blue



## “TOUGHY” DRYER CLEANER

“Toughy” Dryer Cleaner quickly loosens and dissolves the toughest pitch, grease and carbon build-up on veneer dryers.

- Industrial strength
- Easy to use
- Will not burn when applied to hot surface
- Fast acting
- Concentrated cleaning power
- Caustic based

CONVEYOR COMPONENTS

ROLL TUBES & ASSEMBLIES

MAJOR COMPONENTS

DRYER DOORS

GENERAL COMPONENTS

WESTMILL EQUIPMENT

# EXPANSION ROLLER ASSEMBLIES

## EXPANSION ROLLER ASSEMBLIES

Westmill's OEM style expansion roller assemblies will keep your dryer straight and in-line. Easily and quickly retrofitted to any dryer, they are self-guiding and require no maintenance.

Our expansion roller assemblies are designed to be as compact as possible. If your current roller assemblies are taller, simply shim the new Westmill expansion rollers to suit. Field mounting is easy - simply anchor to existing concrete using our optional pre-drilled mounting holes, or weld to existing steel foundation plates.

Our expansion rollers are designed to be directly interchangeable with OEM parts.

### General specifications:

- Overall height: 2 3/4"
- Top and bottom plates: 5/8"-thick steel plates
- Base plate dimensions: 8 " wide by 14 " long (along roller axis)
- Roller diameter: 1 1/2" steel

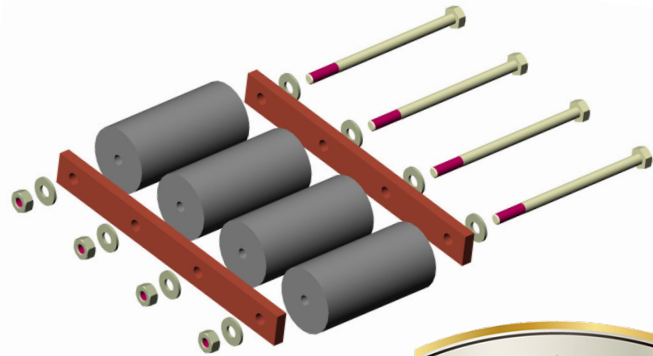

## HIGH CAPACITY STEEL CIRCULATING EXPANSION ROLLER

Westmill's design exclusive Expansion Rollers have captured HD rollers that cannot escape from their housing. These rollers can withstand high static loading over a longer period of time. Made of high-strength steel and built to move, these rollers are ideal even for the heaviest veneer dryer application.

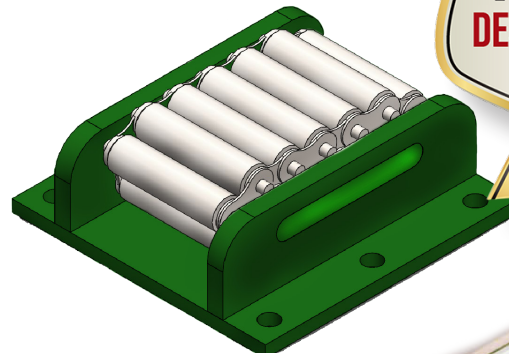

## FOLLOW US ON SOCIAL MEDIA & SUBSCRIBE TO OUR YOUTUBE CHANNEL



SCAN QR CODE

Let's stay connected



WESTMILL™

WESTMILL™  
ELECTRIC INFEED TRIPPLE

WEST  
INFEED CH

CONVEYOR COMPONENTS  
ROLL TUBES & ASSEMBLIES  
MAJOR COMPONENTS  
DRYER DOORS  
GENERAL COMPONENTS  
WESTMILL EQUIPMENT

# ASK ABOUT BULK PRICING

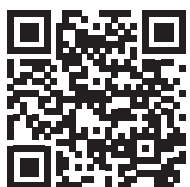

**SHOP ONLINE** | [parts.westmill.com](https://parts.westmill.com)

f @ in ▶

# GLOBE SAW PARTS

## NEW COMPLETE BLOCK CHAIN & V-BLOCK CHAIN ASSEMBLIES & REBUILDS



## CHAIN PARTS & ASSEMBLIES



SIDE BARS & ASSEMBLIES



PINS



LINKS

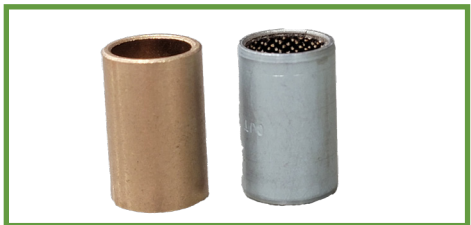

BUSHINGS



ADAPTER LINKS

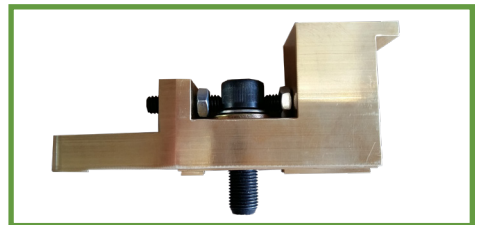

LUGS

## MISC. SAW PARTS

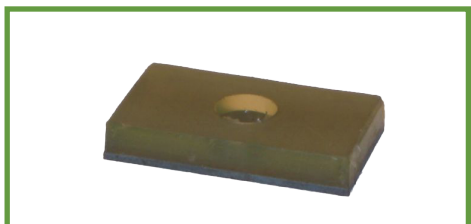

FRICTION PADS

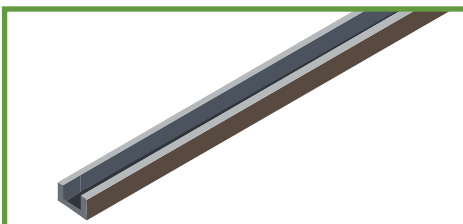

CHAIN GUIDES



SPROCKETS



HOLD DOWN WHEELS



SUCTION CUPS





# WESTMILL<sup>TM</sup> EQUIPMENT



## Westmill Industries provides all major Dryer components and equipment for feeding, & unloading veneer.

Westmill supplies state-of-the-art Veneer Dryers as well as Infeed and Outfeed Equipment. Serving the North American and International plywood industries, Westmill equipment is designed to improve plant efficiency and production.

### Why Choose Westmill?

#### 1. Westmill is the Subject Matter Expert in veneer drying

A family held company since 1975, we successfully compete with multinational corporations. Rather than trying to be experts in other areas of the process, Westmill focuses solely on veneer dryers. Our dedicated focus, combined with an innovative culture has led to a series of incremental dryer improvements. These innovations - conceived, engineered, pioneered, and proven by Westmill are now incorporated into competitors' equipment.

#### 2. Westmill's 'Got your Back' Attitude

Ask the Plant Manager, Project Engineer to the Maintenance Manager why they prefer to deal with Westmill and, overwhelmingly, they will tell you that it is because Westmill has 'Got your Back'. We not only stand behind the equipment we sell, but also squarely behind the customer before, during, and well after the warranty has expired. Westmill provides a level of support that only an independently owned company can.



## INFEED EQUIPMENT

INFEED CHAIN CONVEYOR	58
SCISSOR LIFT (HOIST)	58
ACCUMULATOR	58
VACUUM FEEDER	59
INFEED ROLL CASE	59
HYDRAULIC POWER UNIT	59
ELECTRICALLY ACTUATED INFEED TIPPLE	60

## JET DRYER

DRYER FLOOR	62
EXPANSION ROLLERS	62
UPPER HOUSING (HOT BOX)	62
ROLL ASSEMBLIES	63
JET TUBES	63
DOOR CARTRIDGES	63
STEAM COILS	64
MAXON CROSSFIRE BURNERS	64
HOT-AIR CIRCULATION FAN	64
CHAIN TENSIONER	65
DRIVE TOWER	65
FLOOR WATER MISTING SYSTEM	65
QUICK-CHANGE ROLL BAFFLE	66
COOLING SECTION	66
WESTVAC SEAL SYSTEM	67
2PEX EXHAUST SYSTEM	68
PROGRAMMING & CONTROLS	69
BEARING VIBRATION MONITORING	69

## OUTFEED EQUIPMENT

SEQUENTIAL UNLOADER	71
MULTI-BELT CONVEYOR	71
DOUBLE CROSS-TRANSFER CONVEYOR	72
90° CORNER TRANSFER	72

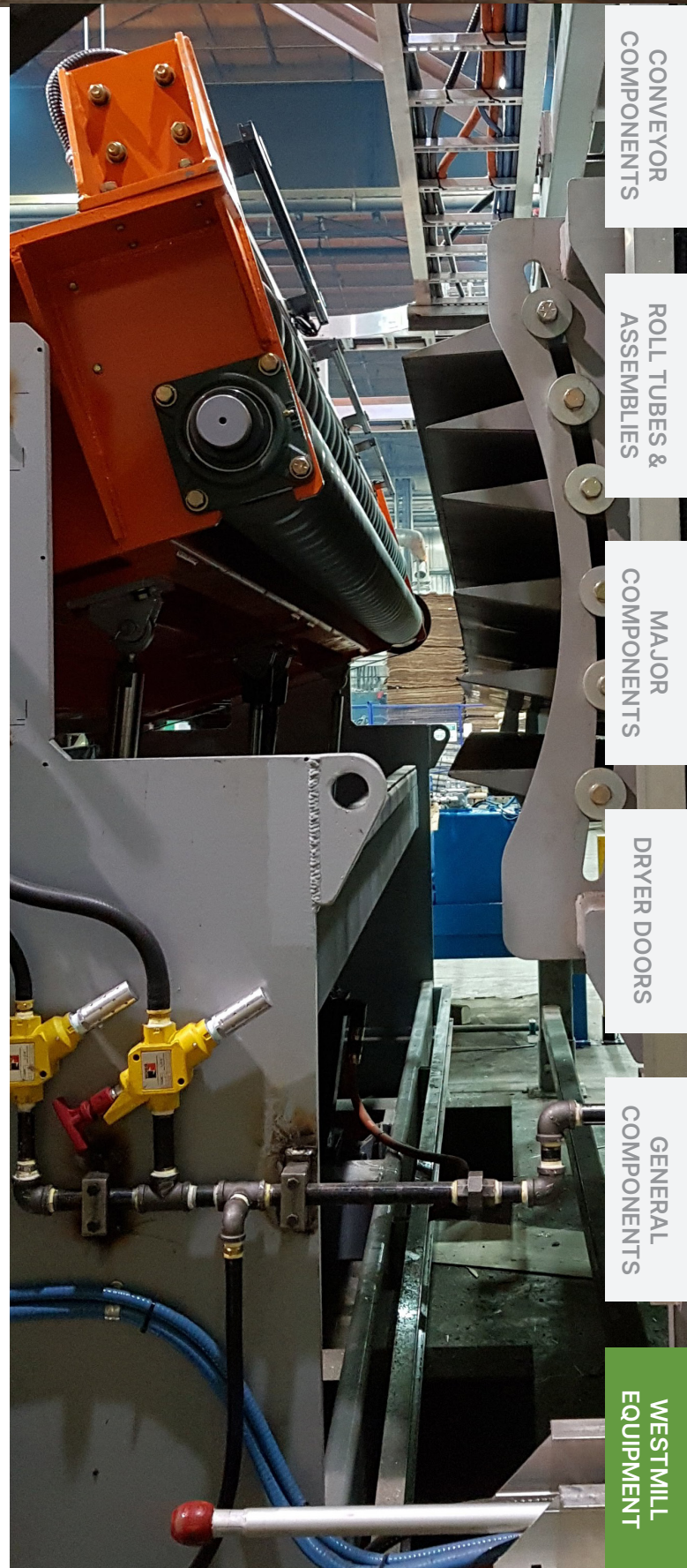

# WESTMILL INFEED SYSTEM

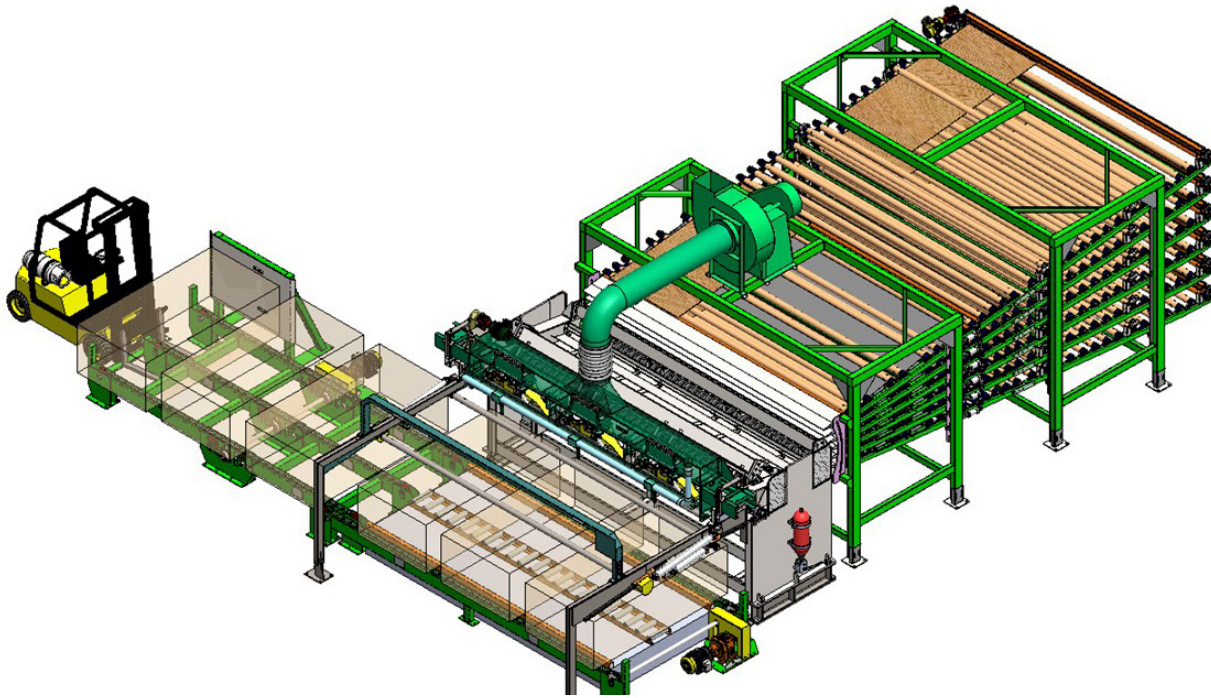

## Westmill offers a complete state-of-the-art dryer Infeed System.

Built using proven components together with technology enhancements that reflect Westmill's constant drive for innovation and performance improvements. Westmill's veneer dryer feeder system can consistently feed over 66 sheets per minute (as compared to 60 sheets per minute by others).

### Infeed Components:

- Infeed Storage Chain Conveyor
- 3-Load Heavy Duty Series Scissor Lift
- Pneumatic Load Accumulator
- Power Feed Roll Vacuum Feeder
- Electric Linear Actuated Feeder Tipple
- Veneer Infeed Rollcase
- Hydraulic Power Unit
- Pneumatic Over Wrappers



## INFEEED CHAIN CONVEYOR

The Westmill Infeed Chain Conveyor senses individual veneer load position as they are placed by the forklift, and automatically indexes each load to match the vacuum feeder head spacing. This helps reduce plug ups while feeding the dryer and helps prevent sheet overlap along 8' edges and corners. Our typical Dryer Infeed Chain Conveyor allows the customer to feed 3 stacks and to store 3 stacks in waiting, ready to load when required, rather than crowding 3 loads tightly together, and breaking valuable veneer.



**DISCOVER MORE**



CONVEYOR  
COMPONENTS

ROLL TUBES &  
ASSEMBLIES

MAJOR  
COMPONENTS

DRYER DOORS

GENERAL  
COMPONENTS

WESTMILL  
EQUIPMENT



## SCISSOR LIFT (HOIST)

The Westmill Dryer Infeed Heavy-Duty (HD) Scissor Lift is rugged and dependable and allows you to support up to 26,000 lbs. of veneer - sufficient capacity for (3) loads of the heaviest green veneer of any species.



**DISCOVER MORE**

## ACCUMULATOR

Westmill's Dryer Infeed Load Accumulator allows for uninterrupted feeding of the dryer during the replacement of the infeed loads. A load replacement can take 45 to 120 seconds depending on the load quality and the efficiency of the operator. With an accumulator, the veneer production through your dryer remains constant with no gaps in production.

Ask for a copy of our Accumulator pay-back calculator.



**DISCOVER MORE**



# WESTMILL INFEED SYSTEM

## VACUUM FEEDER

The Westmill Powered Roll Vacuum Feeder is robust and designed to maintain the highest possible feeding rates. The vacuum is used to pick up the top sheet from veneer loads, then, sheets are automatically advanced forward to the tippel stop gate.



**DISCOVER MORE**



## INFEED ROLLCASE WITH INDEPENDENT DECK DRIVES

Westmill's Infeed Rollcase includes a heavy-duty channel framework and side rails. A separate drive for each deck is included to speed-match the dryer, and to provide much smoother and more consistent dryer feed and overlap timing versus conventional cross-over drive roll arrangement powered from the dryer's main drive chain. A separate drive system also allows you to keep the dryer conveyor operating even when there is an infeed stoppage. If a brief infeed stoppage does occur, Westmill's Infeed Control system automatically activates a "Stop-Gap" function to reduce/eliminate the gap between the last sheet fed into the dryer (pre-stoppage) and the next sheet being fed. This "catch-up" feature is unique in Westmill's infeed control.

## HYDRAULIC POWER UNIT

Westmill's standard Hydraulic Power Unit is well-sized to power your Scissor Lift & Tippel.

### Features Include:

- Vickers or Bosch proportional valve
- Oil immersion heater
- 3/4 HP Cooler Fans
- Tank heaters available

**DISCOVER MORE**



## ELECTRICALLY ACTUATED INFEEED FEEDER/TIPPLE

Westmill has developed a new Electrical Infeed Tipple that has eliminated hydraulic cylinders and HPU in favor of an electric linear actuator.

Using an accumulator to counterweight the tipple feeder head (from 4,000 lbs to only 60 lbs) allows accurate positioning while operating at the industry's highest feed rates.

Westmill has kept many of the same components as found on our original proven Hydraulic Tipple, including the quickly interchangeable pinch wheel head assemblies with solid feeder wheels.

The innovations built into the new Westmill tipple produce the following benefits:

- **Greatly reduced energy consumption** - Counter weight accumulator reduces the required power of the electric actuator vs. hydraulic.
- **Increased sheet feed rate** - Counterweight allows quicker reaction, start-stop times of the linear actuator – can continuously maintain 23+ feeds per minute.
- **Reduced wood breakage** - Adjustable back roll limits bending of the veneer sheet.
- **Increased accuracy** - The tipple head is held in perfect horizontal alignment by a torque-arm and controlled by a servomotor providing absolute positioning accuracy.

**DISCOVER MORE**



CONVEYOR COMPONENTS

ROLL TUBES & ASSEMBLIES

MAJOR COMPONENTS

DRYER DOORS

GENERAL COMPONENTS

WESTMILL EQUIPMENT

# WESTMILL JET VENEER DRYER



## Since 1975, Veneer dryers have been the center of Westmill's focus.

Within the plywood industry Westmill is often referred to as "The Dryer Guys". Westmill's jet veneer dryer will provide you with years of reliable and quality production. With an industry-best warranty, parts supply, maintenance consultations and troubleshooting, Westmill will stand shoulder to shoulder with you. Both during the project, and for years after.

The components listed in this section highlight the key features of our new veneer dryers. Most of these same components can be retrofitted on existing dryers as part of a Westmill Technology Upgrade.

### Dryer Components:

- Dryer Floor & Expansion Rollers
- Upper Housing (Hotbox)
- Roll Assemblies & Jet Tubes
- Door & Door Hardware
- Dryer Heating Equipment
- Hot Air Circulating System
- Chain Tensioner & Drive Tower
- Water Misting System
- Quick-Change Roll-Baffle System
- Cooling Section
- Dryer Humidity Control (WestVac & 2PEX)
- Programming & Controls
- Bearing Vibration Monitoring



## DRYER FLOOR

Westmill dryer floors are manufactured with stainless steel (2-sided) insulated panels for maximum longevity. Anchored in the center, dryers are designed to expand and contract from the center point, lengthwise towards each other.

Westmill pioneered this technology, and was the first company ever to install an insulated stainless steel floor under an existing veneer dryer. Today, Westmill has installed more insulated floors under new and rebuilt dryers than any other company.

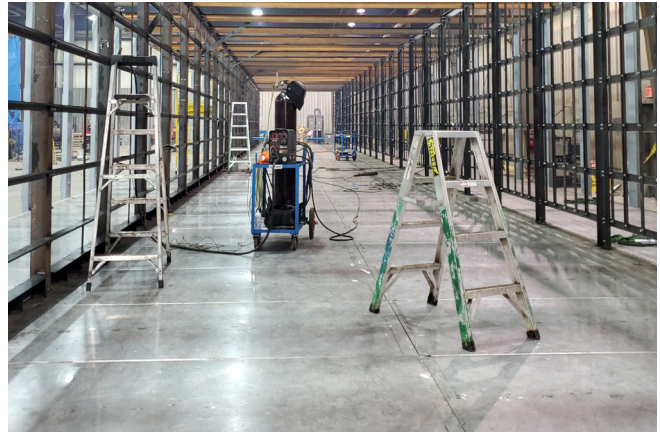

CONVEYOR COMPONENTS

ROLL TUBES & ASSEMBLIES

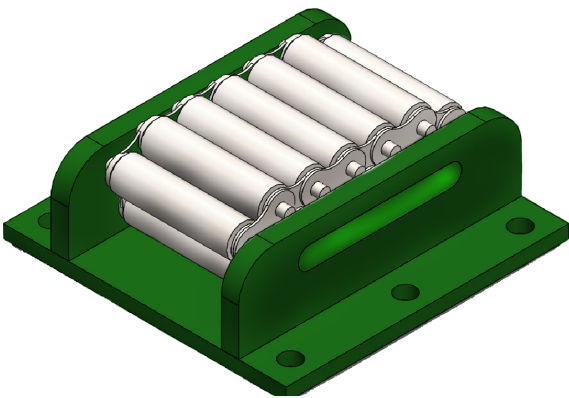

## HIGH CAPACITY STEEL CIRCULATING EXPANSION ROLLER

Westmill's exclusive design of Expansion Rollers have captured HD rollers that cannot escape from their housing. These rollers can withstand high static loading over a longer period of time. Made of high-strength steel and built to move, these rollers are ideal even for the heaviest veneer dryer application.

MAJOR COMPONENTS

DRYER DOORS

## UPPER HOUSING (HOTBOX)

Westmill's "Minimal Heat Transfer" insulated upper housing system is designed to reduce energy costs by virtually eliminating metal-to-metal contact between the inner and outer walls of the dryer's roof and siding. The inner mild steel formed panel system is entirely seal welded to the upper housing framework, then field insulated with 6" of mineral wool before the outer stainless steel cladding is installed.

Compared to conventional flat dryer roofs and side walls, Westmill's Channel Vented roof design allows the dryer housing to "breathe", preventing any condensation from being trapped in the upper housing. This extends the life of the dryer housing by greatly reducing upper-housing corrosion and housing. Allowing the roof to

expand and contract effortlessly as the dryer heats and cools. In addition, because the inner cladding is seal-welded, this roof will not leak like a panelized roof system will.

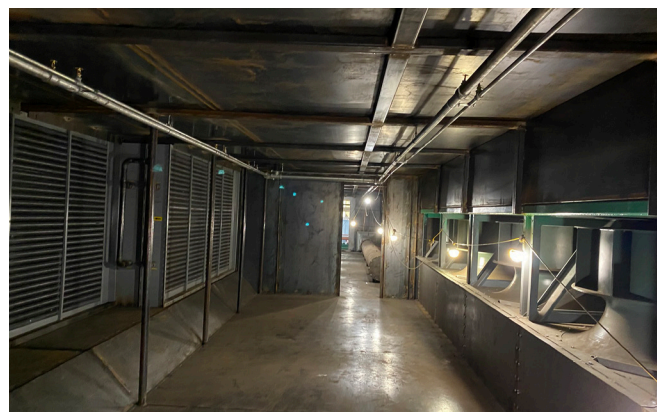

GENERAL COMPONENTS

WESTMILL EQUIPMENT

# WESTMILL JET VENEER DRYER

CONVEYOR  
COMPONENTS

## ROLL ASSEMBLIES

Westmill's Dura-Cast™ Dryer Roll Conveyor System utilizes standard, "off-the-shelf" components available from Westmill. This heavy-duty roll conveyor system includes many components:

- Westmill Graphite Bushings
- Bearing Hangers
- 'Hook-tooth' Sprockets
- Star Gears



*\*Westmill are the only dryer manufacturer to check and straighten every dryer roll tube to within 0.125" run-out, before it leaves our facility.*

ROLL TUBES &  
ASSEMBLIES

MAJOR  
COMPONENTS

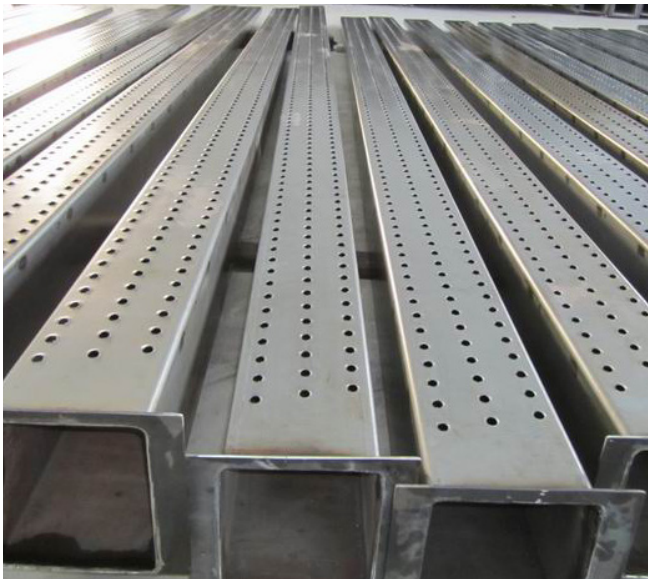

## JET TUBES

Westmill jet tubes are manufactured using 16-gauge sheet metal (while others typically use 18-19 GA). We have also incorporated a heavy 12 GA. flange around the high-pressure opening of the tube to prevent the usual bending and damage caused during handling and thereby maximizing airflow into the jet tube opening. Our jet tubes feature high-velocity orifices for maximum air flow and heat transfer to the veneer.

Westmill also provides adjustable air balancing cover plates to balance the air flow to the individual dryer decks. This allows customers to fine-tune the air flow to each deck, increasing production and reducing over-dry and re-dry rates.

DRYER DOORS

GENERAL  
COMPONENTS

## DOOR CARTRIDGES

The Westmill Pre-assembled Door Cartridge System provides for a quick and easy installation by simply seal welding our heavy wall tubing to the dryer frame and floor.

Westmill provides doors that have 16-gauge 304 stainless steel door skins on both sides. The insulation is 8 lb. mineral wool board insulation and the door is 4" thick; we overlap two separate 2" sheets of insulation so that heat transfer between the seams is eliminated.

Westmill's Patented Dura-Latch™ Articulating Door Hardware provides finite adjustability in all four corners of the door. This door hardware is the most functional and easily adjustable door hardware available on the market today. Our Quick-change 1-2-3 Seal System keeps your dryer well-sealed and allows you to change your door seals in minutes – not hours.

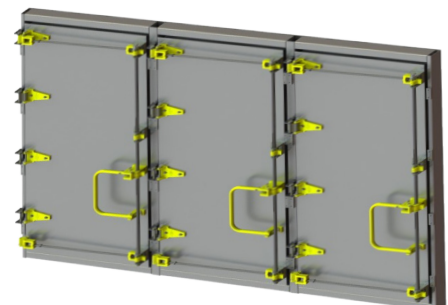

WESTMILL  
EQUIPMENT

## ARMSTRONG-HUNT STEAM COILS

Heating the dryer, Westmill includes hi-efficiency Single Pass steam coils manufactured specially for Westmill by Armstrong-Hunt.

Designed specifically for veneer dryer applications, both the fin and the tube spacing are designed to provide better plug-up resistance than others by allowing debris to pass through the coil bank.



CONVEYOR COMPONENTS

ROLL TUBES & ASSEMBLIES

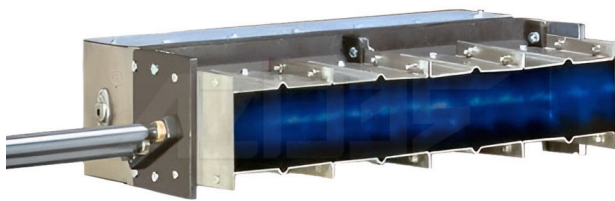

## MAXON CROSSFIRE LOW NOX BURNERS

Maxon Crossfire Burners are nozzle-mixing, modular line burners designed for a variety of fresh and re-circulated industrial air process heating applications. The low NOx burner is available in straight, grid, and insert cartridge sections which are used to spread heat across your duct for very uniform temperature distributions.

One of the most important elements of Maxon's Low NOx burner, is the Maxon Smartlink Micro-Ratio Valve (MRV). Maximized performance while minimizing emissions by allowing independent control of both gas and air at all firing rates.



MAJOR COMPONENTS

DRYER DOORS

## WESTMILL HD REPLACEMENT HOT-AIR CIRCULATION FAN

Westmill fan modules are designed for a quick and easy installation. To reduce installation time, each fan module comes pre-assembled complete with the fan, cone, bearings, sheaves, and spring packing gland. The heavy wall 4" tube-frame is extremely heavily built. Noise and vibration are virtually eliminated with this heavy, welded framework.

Customers have the option of mounting the motors either outboard over the dryer's edge, or inboard over the upper side-wall housing 'step'.

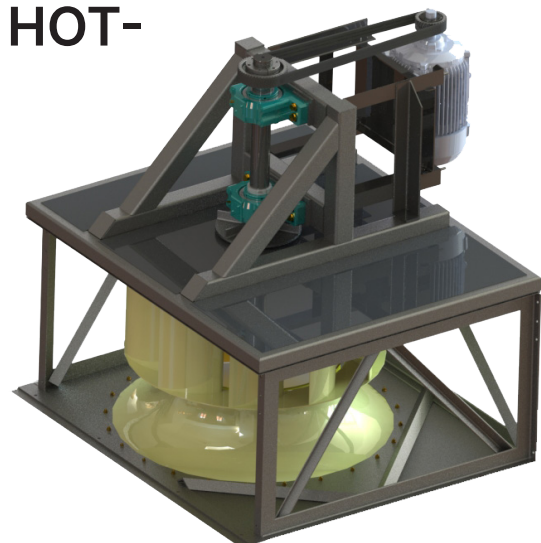

GENERAL COMPONENTS

WESTMILL EQUIPMENT

# WESTMILL JET VENEER DRYER

CONVEYOR  
COMPONENTS

## CHAIN TENSIONER

Westmill's Veneer Pneumatic Chain Tensioner keeps the dryer chain tight and prevents binding. Constant tensioning, along with automatic detection of chain break and jam-up, make our Chain Tensioner a smart solution. Features include:

- Individual slide mounted, Royal Pneumatic Cylinder actuated, chain take-up roller shuttles
- Bearing mounted, 81-X idler sprockets with re-greaseable pins
- Limit switches for "Auto dryer shut-down" if the dryer chain breaks or jams
- Filter, Regulator, Pressure Gauge, Pneumatic Lock Out



ROLL TUBES &  
ASSEMBLIES

MAJOR  
COMPONENTS



## DRIVE TOWER

Maximize veneer recovery and reduce maintenance and downtime with our Dryer Drive Tower. Featuring an independent motor and Variable Frequency Drive for each deck, allowing operators to stop one deck while allowing all other dryer decks to clear before removing the plug-up.

- Provides individual deck speed control
- Plug-up veneer recovery
- Replace old oil-filled gear boxes or chain drive
- Eliminate costly shaft, gear and bearing replacement
- Eliminate downtime and maintenance of oil-filled gear boxes
- Cost effective
- Bolts to existing imbeds

DRYER DOORS

GENERAL  
COMPONENTS

## FLOOR WATER MISTING

A highly effective method has been developed for minimizing dryer fires caused by fuel build up on the dryer floor. The system provides a metered water spray within the dryer to increase the interior dryer humidity level and raise the 'flash point' significantly. The result is a significant reduction of dryer fires normally caused by wood fines in 'tinder-dry' dryer conditions.

Our system provides full floor misting coverage along both sides of the entire dryer's length



WESTMILL  
EQUIPMENT

## QUICK-CHANGE DRYER ROLL BAFFLE SYSTEM **PATENTED**

Properly fitted Stop-off Roll Baffles seal the ends of the dryer. However, Dryer Roll Baffles (Stop-Off Walls) are one of the most overlooked areas for dryer maintenance or attention.

When baffles wear and gaps are created between the roll and the baffle face, gases are free to move in/out of the dryer depending on its operation. This has a substantial effect on production, energy usage, pitch build-up, fires, and poor veneer quality.

- **CASE STUDY:** On each 15' dryer roll, a 3/8" gap between the Roll Baffle and the roll itself equals 67.5 sq. inches of total opening
- On a 6 deck dryer, the total "opening" in the end of a dryer is 5.63 sq ft

To help prevent these problems, Westmill has designed and successfully installed the Quick-Change Dryer Roll Baffle System for Westmill Jet Dryers.



Quick Install

In comparison to changing existing roll baffles, removing, and replacing an entire roll-baffle set now takes under 1-hour vs. ~16-20 man-hours of very labor-intensive work.

A unique feature of this innovation is that you are not required to remove the existing rolls, chain, sprockets, star gears or jet tubes to replace the Roll Baffles - they all stay in place.

The main benefits of properly sealing the end walls of your dryer are:

- Control of emissions from the end of the dryer
- Reduced dryer exhaust emission volumes
- Reduced pitch build-up
- Conserve energy
- Reduced incidence of fires
- Improved veneer quality by increasing humidity levels inside the dryer

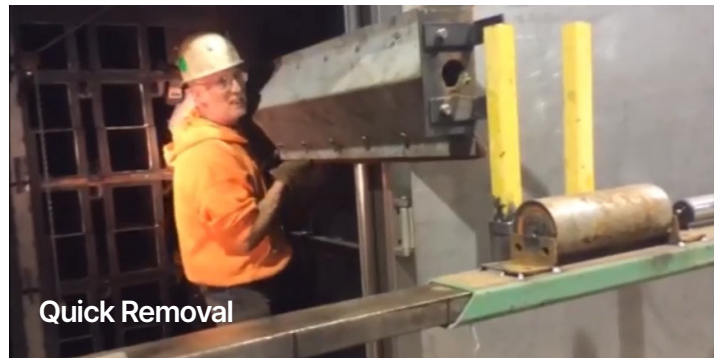

Quick Removal

## WESTMILL DRYER COOLING SECTION

The cooling sections of WESTMILL dryers are configured with BOTH intake and exhaust vane axial fans. We suggest incorporating VFD's on these fans to enable greater control of cooling requirements while providing decreased energy consumption during cooler months, and increased cooling during the hottest months.

Westmill has configured the first cooler intake stack to allow plant air to be used for cooling during extremely hot summer months.

The jet tubes used in the cooler zones are the same as in the dryer hot sections. These have been proven to more effectively deliver the cooling air to the veneer to effectively reduce the veneer's temperature before leaving the dryer.

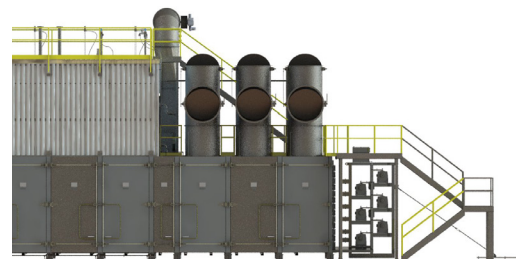

CONVEYOR COMPONENTS

ROLL TUBES & ASSEMBLIES

MAJOR COMPONENTS

DRYER DOORS

GENERAL COMPONENTS

WESTMILL EQUIPMENT

# WESTMILL JET VENEER DRYER

## DRYER HUMIDITY & EMISSION CONTROL SYSTEMS

A Westmill dryer comes with the most advanced, effective and proven Dryer Humidity and Emission Control system (Patented) available in the market today.

Westmill's two Dryer Humidity and Emission Control systems operate together to control humidity along the entire dryer's length while eliminating fugitive emissions from leaking out from the Green and Dry-ends of the dryer.

The two systems are called:

1. **WestVac™ - Dryer Emission Control & Seal System**
2. **2-PEx™ - Two Point Exhaust, Dryer Humidity Control & Exhaust Management System**

## WestVac™ DRYER EMISSION & SEAL SYSTEM **PATENTED**

Westmill's Patented WestVac™ Dryer Emission Control & Seal System seals the dryer's end walls to limit any dryer emissions from leaking out of the green-end and dry-end of the dryer while maintaining the optimum humidity level inside the dryer.

An effective method of controlling end-wall dryer emissions while increasing production, saving energy, improving veneer quality, and reducing the risk of dryer fires. We currently have this system working on over 20 veneer dryers across North and South America, with more under contract.

All of this is accomplished via the system's Re-Intro-Duct which draws any escaped heat-energy, VOCs and humid dryer gases back into the drying chamber by way of low-pressure vacuum created by the main circulation fans. The amount of vacuum in the system is adjustable and can be automatically or manually operated.

### WestVac™ System Benefits Include:

- Increased dryer production
- Greatly improved veneer quality
- Reduced energy consumption
- Reduced risk of fire
- Reduced in-plant emissions
- Increased dryer humidity ratio

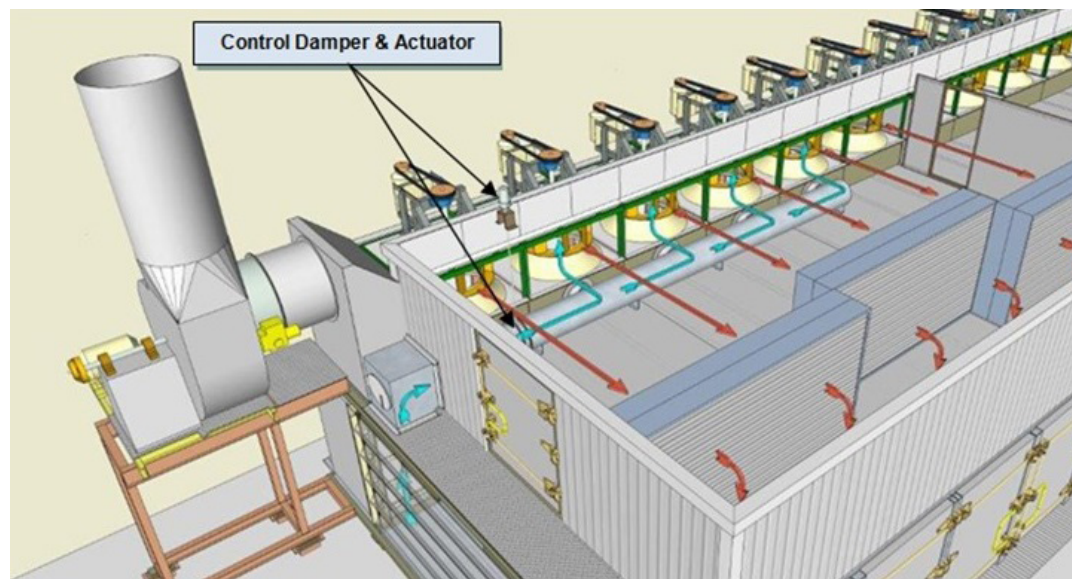

CONVEYOR  
COMPONENTS

ROLL TUBES &  
ASSEMBLIES

MAJOR  
COMPONENTS

DRYER DOORS

GENERAL  
COMPONENTS

WESTMILL  
EQUIPMENT

## 2PEX™ DRYER HUMIDITY CONTROL & EXHAUST SYSTEM

**PATENTED**

The 2PEX™ System provides unparalleled control of the humidity ratio along the entire dryer's length resulting in the BEST veneer quality available of any dryer sold today.

Quite simply, by providing separate extraction points at BOTH the Green-end and the Dry-end of the dryer, we can control the humidity migration towards either or both ends of the dryer vs. venting the entire dryer's exhaust from a Green-end SPE (Single Point Exhaust), thereby starving the Dry-end for moisture

(common on Jet dryers with Single Point exhaust systems operating today).

By pulling the high humidity from the Green-end down to the Dry-end, the 2PEX™ provides higher average humidity-ratio along the entire dryer. This higher humidity increases 'flash-point', reducing fires, providing higher temperature drying, increasing production and veneer quality.

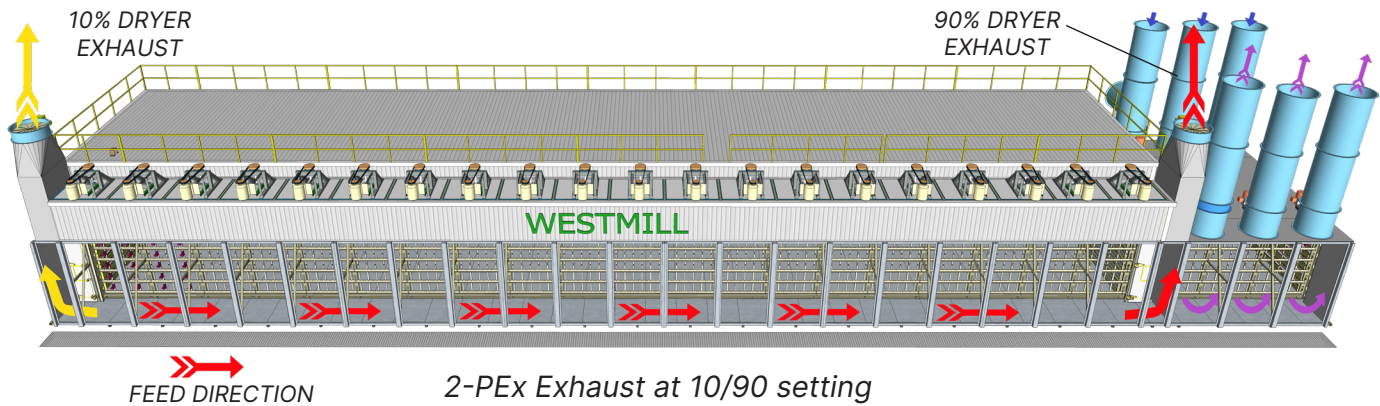

CONVEYOR COMPONENTS

ROLL TUBES & ASSEMBLIES

MAJOR COMPONENTS

DRYER DOORS

GENERAL COMPONENTS

WESTMILL EQUIPMENT

# WESTMILL JET VENEER DRYER

## PROGRAMMING & CONTROLS

Westmill's Dryer Control System functionality, ease-of-use and reliability is so highly regarded that we have customers that have standardized this system across operations in multiple locations – even for dryers not originally built by Westmill. We use the most current version of Allen Bradley ControlLogix and Panelview Touchscreens (unless otherwise requested by our customer).

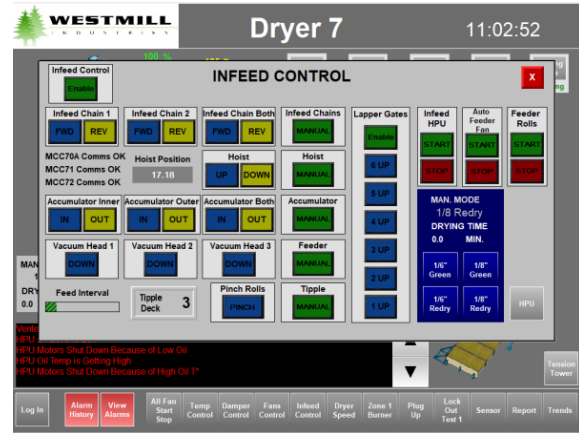

## VIBRATION MONITORING & BEARING EARLY WARNING FAILURE SYSTEM

Westmill has identified and pioneered an easy-to-incorporate solution that significantly and effortlessly enhances a plant's preventative maintenance regime while increasing a dryer's uptime.

This solution incorporates vibration monitoring sensors and networked feedback of the gathered data to provide real-time monitoring of all the main circulation fans and all cooler fans.

This real-time monitoring for out of tolerance vibration in critical bearing applications provides a maintenance worker with advanced warning of a pending bearing failure.

For absolute simplicity, this system provides a real-time visual color-matrix indicator showing a GREEN (all OK), YELLOW (Check at next scheduled PM event) or RED (Check now) for every bearing being monitored.

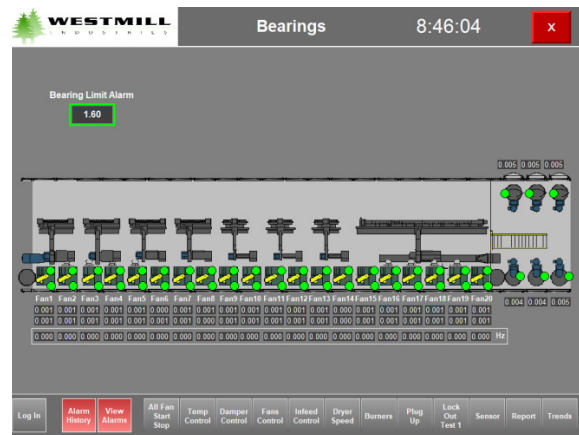

1	2	3	4	5	6	7	8	9	10	11	12	13	14	15	16	17	18	19	20
21	22	23	24	25	26	27	28	29	30	31	32	33	34	35	36	37	38	39	40
41	42	43	44	45	46	47	48	49	50	51	52	53	54	55	56	57	58	59	60
61	62	63	64	65	66	67	68	69	70	71	72	73	74	75	76	77	78	79	80
81	82	83	84	85	86	87	88	89	90	91	92	93	94	95	96	97	98	99	100
101	102	103	104	105	106	107	108	109	110	111	112	113	114	115	116	117	118	119	120
121	122	123	124	125	126	127	128	129	130	131	132	133	134	135	136	137	138	139	140
141	142	143	144	145	146	147	148	149	150	151	152	153	154	155	156	157	158	159	160
161	162	163	164	165	166	167	168	169	170	171	172	173	174	175	176	177	178	179	180
181	182	183	184	185	186	187	188	189	190	191	192	193	194	195	196	197	198	199	200
201	202	203	204	205	206	207	208	209	210	211	212	213	214	215	216	217	218	219	220
221	222	223	224	225	226	227	228	229	230	231	232	233	234	235	236	237	238	239	240

CONVEYOR COMPONENTS

ROLL TUBES & ASSEMBLIES

MAJOR COMPONENTS

DRYER DOORS

GENERAL COMPONENTS

WESTMILL EQUIPMENT

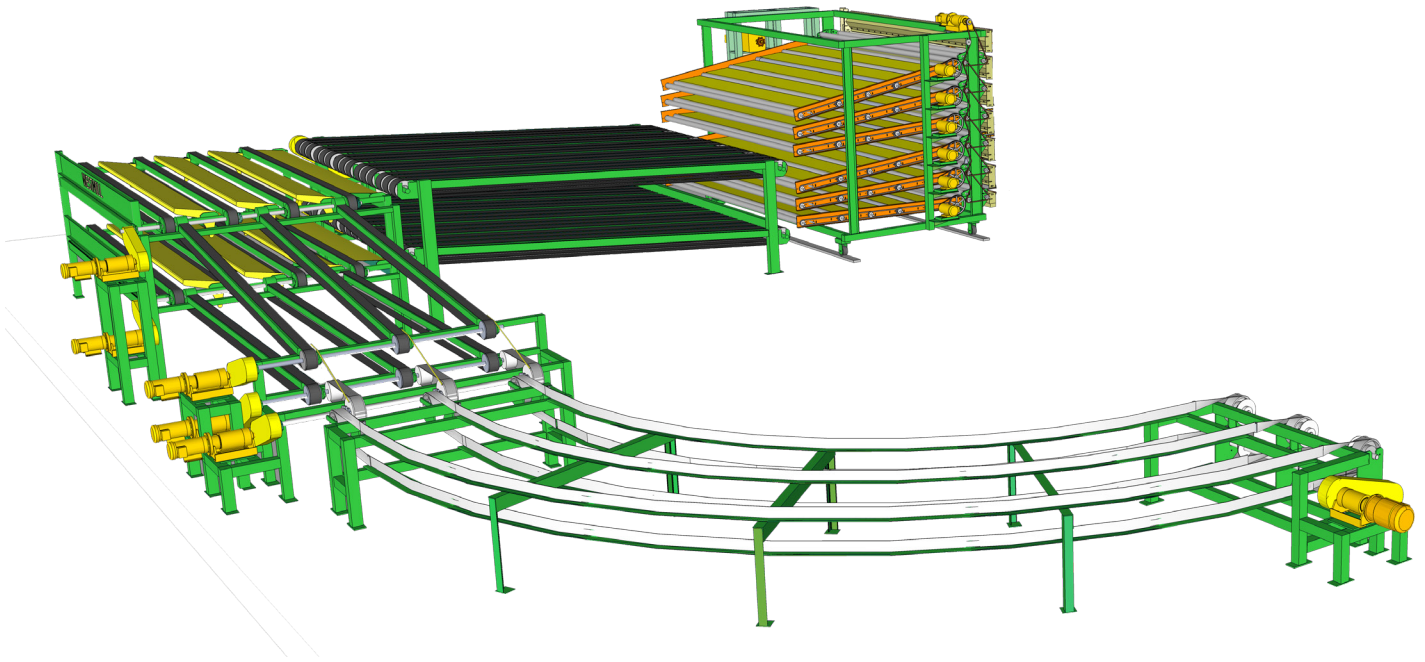

## Westmill offers a complete state-of-the-art dryer Outfeed System.

The Dryer Outfeed system quickly unloads the veneer sheets from the dryer, merges all decks onto a single belt, and conveys the veneer to the Veneer Grading line. Westmill's system makes this process as quick as possible while minimizing sheet skew.

### Outfeed System Components:

- Sequential Unloader
- Multibelt Conveyor, 2-Level
- Cross-Transfer Conveyor, 2-Level
- Transfer Merge Conveyor, 2-Level
- Conveyor, 90° Edge Belt



# WESTMILL OUTFEED SYSTEM

CONVEYOR  
COMPONENTS

ROLL TUBES &  
ASSEMBLIES

MAJOR  
COMPONENTS

DRYER DOORS

GENERAL  
COMPONENTS

WESTMILL  
EQUIPMENT

## SEQUENTIAL UNLOADER

Proper sequential unloading reduces dryer outfeed plug-ups and results in more consistent grading and reduces veneer sheet damage, especially at higher veneer processing speeds. Sheets are removed from the dryer as soon as they are detected, thus optimizing the system speed to its fullest.

### Pinch Rolls & Veneer Detection

The infeed of the sequential unloader features two pairs of pinch rolls at the infeed of each deck. The pinch rolls rotate faster than the dryer rolls, thus pulling the sheets from the dryer and creating a gap between the unloader and the dryer.

### Speed Up Rolls

Westmill's Sequential Unloader is unique with our larger bottom roll design. The bottom roll of the unloader pinch rolls is 5" inches in diameter for extra stiffness and reduced deflection. It's important that minimal gap be visible between the rolls of a pinch roll pair for consistent unloading.

### Ejection Rolls

Each of the unloader decks features an independent set of sheet discharge rolls to quickly evacuate sheets onto the multibelt.

### "V" Groove Wheel & Track

The Sequential Unloader can be supplied with two foundation wheel tracks, which permit the unloader to be wheeled away from the dryer outfeed end wall for cleanout, baffle replacement/adjustment and/or roll replacement.

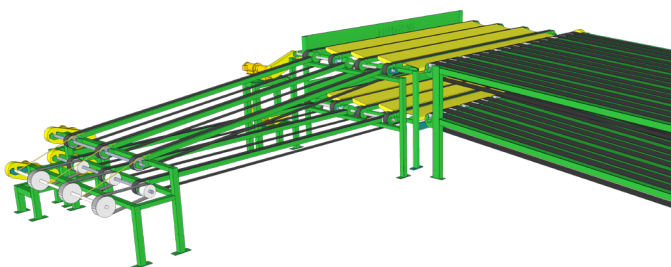
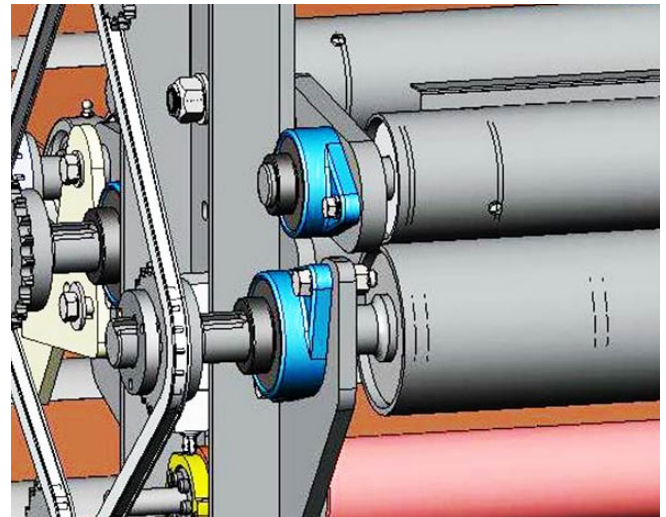
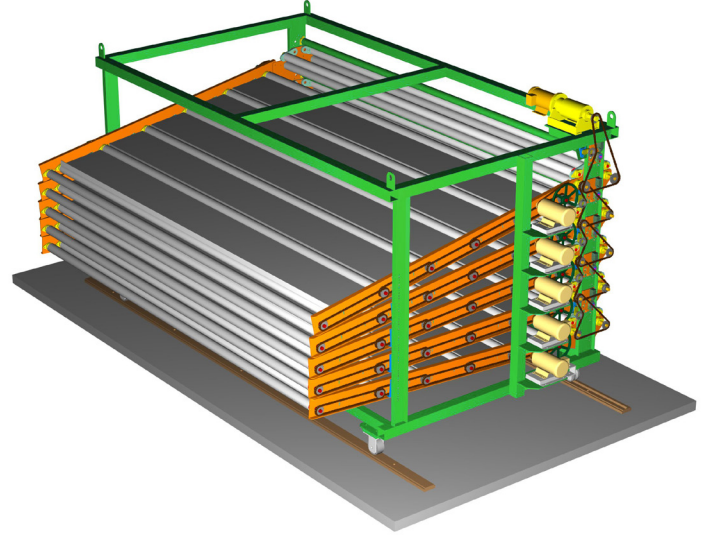

## MULTIBELT CONVEYOR

Each Multibelt Conveyor includes multiple 6" wide 3 ply rough top conveyor belts. The approximate width of the conveyor is 18 feet. The conveyor includes the drive assembly framework mounted to one-leg assembly.

## DOUBLE CROSS-TRANSFER CONVEYOR

Veneer is 'launched' from the Multi-belt Conveyor to the Double Corner Transfer Conveyor. With the drop pans in the up position, veneer skids along the tops of the pans and strikes the spring backstop.

After contacting the spring backstop, the drop pans pivot down and the veneer is quickly taken away via the continuously running rough-top belts to the merge conveyor section.



CONVEYOR COMPONENTS

ROLL TUBES & ASSEMBLIES

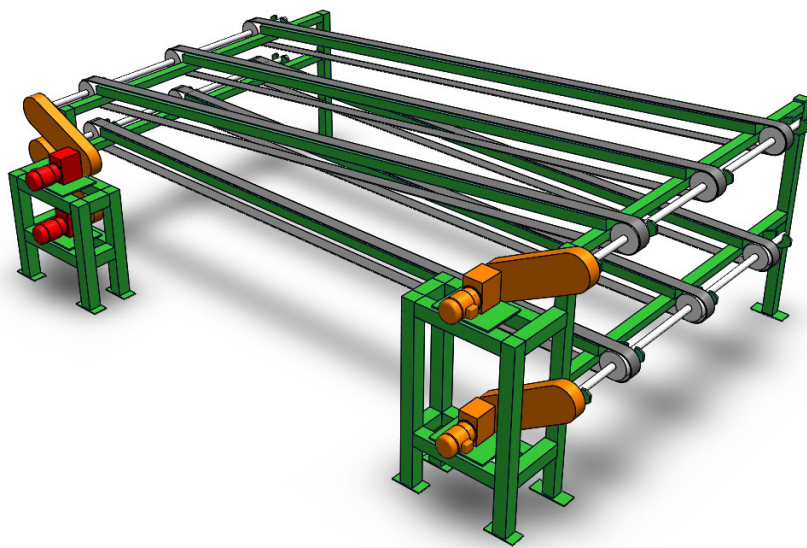

## MERGE CONVEYOR 2-TO-1 LEVEL

With sheet positioning sensing and individual VFD control, the Westmill Merge Conveyor helps to stage veneer prior to scanning and stacking.

MAJOR COMPONENTS

DRYER DOORS

## 90° CORNER TRANSFER

Westmill's 90-degree Edge Belt Corner Transfer includes all drives and take-ups.



GENERAL COMPONENTS

WESTMILL EQUIPMENT

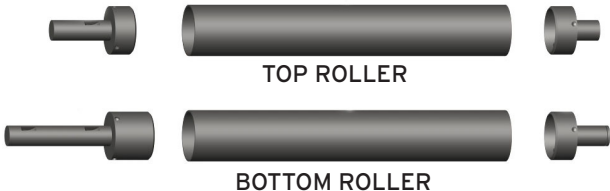
<b>DRYER NO:</b>		<b>DRYER NOTES</b>
<b>MAKE:</b>	<b>YEAR:</b>	
<b>CONVEYOR COMPONENTS</b>		<b>DRYER DOOR HARDWARE</b>
		SEAL TYPE:
		DOOR SIZE:
		DOOR HARDWARE:
		'SAFE-OPENING' DOOR HARDWARE':
		<b>MAJOR COMPONENTS</b>
<b>ROLL TUBE ASSEMBLIES</b>		JET TUBES:
 <p>TOP ROLLER</p> <p>BOTTOM ROLLER</p>		
		PLUG FANS:
<b>TOP ROLL:</b>	<b>BOTTOM ROLL:</b>	<b>GENERAL COMPONENTS</b>
<b>BUSHINGS:</b>		PLUG-UP DETECTION:
<b>SPROCKET: (DRIVE SIDE)</b>		
<b>SPROCKET: (IDLER SIDE)</b>		MOISTURE DETECTION:
<b>BEARING HOUSING: (DRIVE SIDE)</b>		
<b>BEARING HOUSING: (IDLER SIDE)</b>		MARKING INK:
<b>NOTES:</b>		

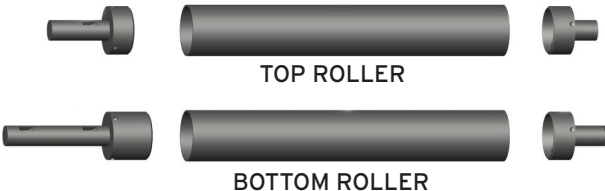
<b>DRYER NO:</b>		<b>DRYER NOTES</b>
<b>MAKE:</b>	<b>YEAR:</b>	
<b>CONVEYOR COMPONENTS</b>		<b>DRYER DOOR HARDWARE</b>
		SEAL TYPE:
		DOOR SIZE:
		DOOR HARDWARE:
		'SAFE-OPENING' DOOR HARDWARE':
		<b>MAJOR COMPONENTS</b>
<b>ROLL TUBE ASSEMBLIES</b>		JET TUBES:
 <p>TOP ROLLER</p> <p>BOTTOM ROLLER</p>		
		PLUG FANS:
<b>TOP ROLL:</b>	<b>BOTTOM ROLL:</b>	<b>GENERAL COMPONENTS</b>
<b>BUSHINGS:</b>		PLUG-UP DETECTION:
<b>SPROCKET: (DRIVE SIDE)</b>		
<b>SPROCKET: (IDLER SIDE)</b>		MOISTURE DETECTION:
<b>BEARING HOUSING: (DRIVE SIDE)</b>		
<b>BEARING HOUSING: (IDLER SIDE)</b>		MARKING INK:
<b>NOTES:</b>		

# WESTMILL™

---

[parts.westmill.com](http://parts.westmill.com) | [sales@westmill.com](mailto:sales@westmill.com) | 1-877-607-7010

WAREHOUSES: Atlanta, GA | Eugene, OR | Vancouver, BC